

MT12000 MetroTune Operating Guide

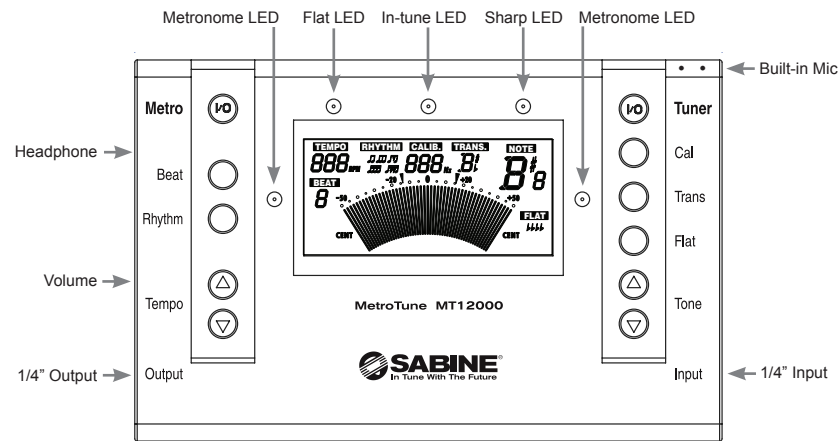

Tuner and Metronome functions operate simultaneously

Metronome Functions:

- Metro:** Turns metronome functions on and off.
- Beat:** Beats per measure for accented downbeat
- Rhythm:** Five different rhythm figures
- Tempo:** Beats per minute in 1 beat increments

For Both Tuner and Metronome:

- Headphone:** Metronome beats or tone generator
- Volume:** Metronome beats or tone generator

Tuner Functions:

- Tuner:** Turns tuner functions on and off.
- Cal:** Calibrate to specific frequency
- Trans:** Transpose the tuner to any key
- Flat:** Flat tune your instrument
- Tone:** Five octaves of tones for tuning by ear.
- 1/4" Input & Output:** Plug in instrument for tuning
- Built-in Mic:** Picks up instrument for tuning

Metronome Instructions

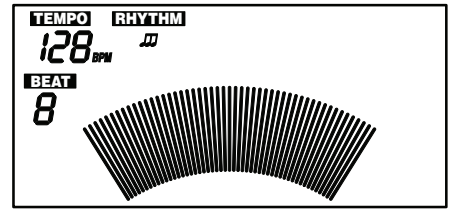

POWER

Press and hold the METRO (I/O) button on the left side of the MT12000 to power the Metronome on.

TEMPO

The tempo of the metronome is displayed in Beats per Minute (BPM). Change the tempo by pressing the up or down tempo buttons. Your setting is displayed in the upper left hand corner of the LCD display under TEMPO. Tempo ranges from 40 to 208 BPM and can be adjusted in single increments. The MT12000 gives you visual LED cue on either side of the LCD, a swinging LCD indicator, and a wood-block tone. Turn the volume all the way down for visual only indication.

BEAT

You can add an Accented Downbeat by pressing the BEAT button. Choose from 0 (no accented beat) to 7 beats per measure. Your setting shows in the display in the left hand corner under BEAT. This is great for adding the "one" to the beginning of each measure.

RHYTHM

Press the RHYTHM button to select one of six available rhythm figures. Your setting is displayed in the upper left hand corner under RHYTHM. Each beat in the measure will get the assigned rhythm figure.

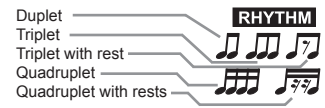

VOLUME

Change the volume by turning the volume wheel on the left side of the unit.

USING THE TUNER AT THE SAME TIME

You can turn on the power for the Tuner and tune your instrument at the same time the metronome is functioning. You may want to plug in your instrument or turn down the Metronome volume in order to use both functions at the same time.

Tuner Instructions

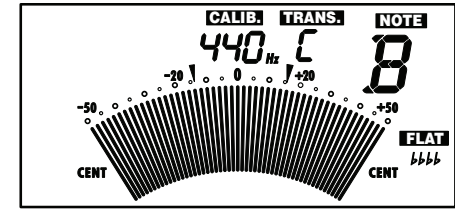

POWER

Press and hold the TUNER (I/O) button on the right side of the MT12000 to power the Tuner on.

TUNING

Using either the 1/4" jack input or the built-in microphone, play the note you wish to tune. The name of the note shows in the upper right of the display. The MT12000 gives you three visual cues for tuning: LCD needle, LEDs, and the two-color backlight. The left LED shows red when the note is flat and the right LED shows red when the note is sharp. Both the red and green LEDs turn on as the note approaches being in tune, and the green LED lights alone when the note is in tune. The backlight of the LCD display is orange when the note is flat or sharp and turns green when in tune. Adjust your instrument so that the needle is at 0 cents and the LED and LCD backlight are green.

CALIBRATION

Press the CAL button until the desired frequency appears under CALIB on the LCD. The tuner's scale is now shifted to that pitch. To return the tuner to standard A=440 Hz, press the CAL button until 440 shows in the LCD display.

TOUR GENERATOR

Press the TONE up or down buttons to select the note you want to hear. The tone generator range is E1 to C6. The volume wheel adjusts the loudness. Insert a headphone in the jack for listening, which turns the speaker off. To turn the tone off, press the Tuner I/O button.

TRANSPOSE

Press the TRANS button to transpose the tuner to match the key of your instrument. If you play a trumpet, clarinet or other Bb instrument, press the TRANS button until Bb shows under TRANS on the LCD. Flutes, oboes, violins and most fretted instruments like guitars are C instruments.

FLAT TUNE

Flat tune aids when you wish to tune your fretted instrument with a capo. If your capo is on the third fret, press the Flat button until you see three flats (bbb) under FLAT on the LCD. Tune to E,A,D,G,B,E as usual. The range for flat tuning is from 0 to 4 flats.

Features, Specifications, Warranty

Metronome features

- Loud, wood block tone
- Volume control (continuous)
- Sweeping pendulum LCD & LED display
- Mini Plug Earphone jack
- One beat metronome increments
- Accented Beats: 0, 1, 2, 3, 4, 5, 6 and 7 beats per measure
- Common Rhythm Figures: Duplet, Triplet (with & without rest), Quadruplet (with & without rests)

Tuner features

- Chromatic, Automatic
- Two-color LCD with simulated needle display, +/- 50 cents
- Two-color LED display
- Manual calibration, 430 to 450 Hz
- Mic for acoustic tuning
- 1/4" input for instrument tuning
- Large note indicator
- 7-octave tuning range (A0 to B7)
- Auto-shut off after 3 minutes with no signal
- Tone Generator, for tuning and ear training
 - Volume control
 - 4-octave range (E1 to C6)

Mechanical

- Dimensions: W=4.7 in., H= 3.1 in., D=0.65 in. (12 cm x 7.9 cm x 1.7 cm)
- Weight: 4 oz. (113.4 grams)
- Removable stand for desktop and music stand viewing

Batteries: 2 AAA (included)

Memory

- All settings recalled from power-down

Limited Two-year Warranty

If your MetroTune fails because of a manufacturing defect within two years from the date of the original purchase, please return it to your dealer. If you need to return the tuner to Sabine, call for a Return Authorization number. Then send it, postage prepaid, to Sabine for replacement with a new or reconditioned product. You must include your full name, address, proof of purchase and the nature of the defect. This warranty does not cover damage caused by accident, misuse or defective batteries.

Register Online

Register your Sabine products online at:
www.Sabine.com

SABINE, INC.

13301 Highway 441 Alachua, FL 32615-8544 USA
Phone: (386) 418-2000 FAX: (386) 418-2001

www.Sabine.com
sabine@Sabine.com



Made in China
© 2010 Sabine, Inc.

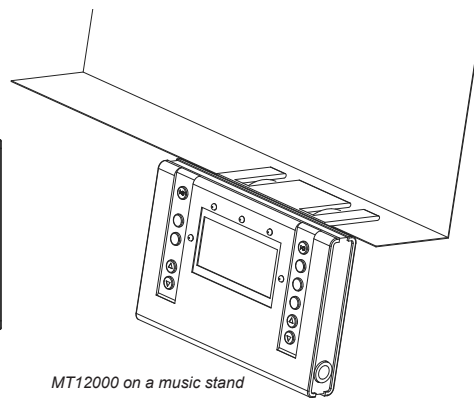
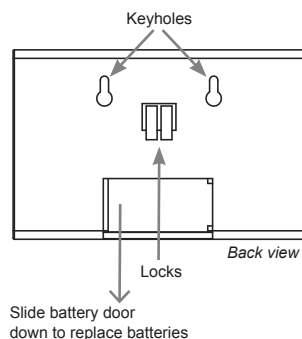

Using the stand on your MetroTune MT12000

Install the MT12000 stand by inserting the posts of the stand in the keyholes in the back of the MT12000 and sliding up until it locks in place. Remove the stand by pressing the two locks in and sliding the stand out of the keyhole. Mount the stand on a music stand or lean it back on a desktop.

Changing batteries on your MetroTune MT12000

Slide the battery door down to replace the two AAA batteries.

Intonation Training and Tuning Tips

Intonation for Wind & Orchestra Instruments

Use the MT12000 to track every note you play. Try playing a simple passage and see how close to "in-tune" each note is. Strive to get every note as close as possible to in-tune!

Stringed Instrument Tuning Tips

Many musical instruments have peculiarities that cause annoying tuning problems. Most of these peculiarities are overcome by following these simple procedures:

- Pluck one string at a time.
- Pluck the instrument once per second to keep the note "fresh" while you are tuning. Notes go noticeably flat a second or two after being plucked. If tuning a higher-pitched instrument (such as a mandolin), pluck a little faster; for a lower-pitched instrument (such as a bass), pluck slower.
- Do not pluck loudly. Generally light to medium volumes provide purer tones that are easier for tuners to analyze.
- Pluck the strings with the flesh of the thumb. Fingernails and flat picks add overtones and slow the tuning process.
- Tune from a pitch that is flat up to the pitch you desire. This procedure removes any slack in the gears of the instrument's tuning heads. If you tune from sharp to in tune, the gears will slip as you play, and the instrument will go flat after a few minutes of playing.
- If you have difficulty getting a note to register on the tuner, try touching the other strings lightly to stop their sympathetic vibrations. This will eliminate any extraneous overtones that may disturb the tuning.

- Use good strings. Old strings lose their uniformity and do not vibrate evenly. New strings stretch flat as you play.

- All sources of friction cause tuning problems. For example, if the slot in an instrument's nut is too tight, the string will be pulled flat as it is played. A tight nut (or capo) will cause the string's pitch to change in steps rather than evenly.

- Avoid pressure on the instrument while tuning. Even moderate pressure on the neck of a guitar will cause a noticeable change in pitch. Also, press the strings straight down to the fingerboard. Bending the strings sideways is very common, especially on difficult chords, but causes the strings to be pulled sharp.

- A note for advanced fretted instrumentalists: Almost all fretted instruments, and most other instruments, are constructed to play an "even-tempered scale." Sabine tuners are also calibrated to this scale. The even-tempered scale places equal tonal spacing between all notes in the scale so that the musician will not have to retune to change keys. A disadvantage, however, is that the third note of the scale sounds a little sharp (14 cents, to be exact). For example, when playing in the key of G, the B note will sound sharp. If you tune the B string so that it sounds correct in an open G chord, other chords using the B string will sound out of tune. The musician may choose to optimize the tuning of a particular key or to use the even-tempered scale. Much depends on the musician's style, but generally it is best to tune exactly as your MetroTune indicates.