

Summary of Features

NAV3600 (3 x 6 System Processor)

NAV4800 (4 x 8 System Processor)

NAV8800 (8 x 8 System Processor)

NAV3600-EN (3 x 6 System Processor, with Ethernet)

NAV4800-EN (4 x 8 System Processor, with Ethernet)

NAV8800-EN (8 x 8 System Processor, with Ethernet)

Navigator Remote for Windows™ Software included with every unit; runs up to 16 Navigators

- Full front panel control
- 24-bit A/D and D/A conversion, 40-bit extended processing
- 20 to 20 KHz Frequency Response
- +18 dBu Maximum Signal Input & Output
- Floating Point SHARC Processor
- 115 dB dynamic range

Each Input/Output channel provides

- Precise control of Level and Polarity
- Parametric Filters: up to 6 filters, numeric or graphic control
- Crossover: Bessel, Butterworth, and Linkwitz Reilly filters; slopes to 48 dB/octave
- High Shelf Filter (3KHz to 20KHz) and Low Shelf Filter (20 Hz to 1KHz)
- FBX Feedback Exterminator: 8 Filters, with Setup Mode
- Compressor/Limiter, with controls for ratio, threshold, attack, release, and gain
- Digital Delay, with up to 450 msec delay, adjustable in 20 microsecond increments
- Bypass: dedicated switches for all functions
- Mute and Channel buttons, with easy linking
- LED Indicators: Gain/Menu, Mute, Level
- LCD Display: All parameters and status displays
- Store up to 30 programs
- Multiple levels of password security

Back Panel:

- XLR inputs & outputs; Phoenix on 8800 units
- RS-232 Serial input
- Ethernet (-EN units only)

Navigator Remote Software Features:

All front panel controls, plus more, including:

- Graphic filter adjustments
- Password protection
- View & edit frequency response curves
- Store and recall files, setups, programs
- Control and link up to 16 Navigators (-EN units)
- Future-proof FREE Flash RAM upgrade capability: upgrade your firmware and software using Sabine's Upgrade Wizard

Operating Guide Version 2: for Sabine Navigators with:

- Navigator Firmware Version 5.04 and up
- Navigator Remote Software Version 5.0 and up

EC - DECLARATION OF CONFORMITY

CE MARKING

We, the Manufacturer

SABINE, INC.
13301 NW US HIGHWAY 441
ALACHUA, FLORIDA USA

declare that the product

EQUALIZER
SABINE MODEL NAVIGATOR

Is in conformity with

Council Directive: 73/23/EEC and 89/336/EEC (EMC Directives)

Standards to which conformity is declared:

EN 60065: 1993

EN 60742: 1995

EN 55103-1: 1997

EN 55022: 08:94 + a1:05:05

EN 55103-2: 1997

Manufacturer's Signature: _____



Date: SEPTEMBER 30, 2005

Name: Doran Oster, Sabine President

Table of Contents

Summary of Features	1
Section One: Introduction	4
Section Two: Front & Back Panel Views	5
Section Three: Navigator Applications	6
3.1 INSTALLED AUDIO	6
3.2 PRODUCTION AUDIO	7
Section Four: Using Navigator Front Panel Controls	8
4.1. QUICK START GUIDE TO THE NAVIGATOR FRONT PANEL	9
Section Five: Operating the Navigator	10
5.1 INPUT MENUS	10
5.2 OUTPUT MENUS	12
5.3 SYSTEM MENUS	14
5.4 INPUT/OUTPUT REFERENCE GUIDE	16
5.5. FEEDBACK CONTROL AND PARAMETRIC EQUALIZATION	17
5.6. FBX OPERATING INSTRUCTIONS	18
Section Six: Using Navigator Remote Software	20
6.1. SYSTEM REQUIREMENTS AND RECOMMENDATIONS	20
6.2. CONNECTIONS	20
6.3. INSTALLING AND USING THE SOFTWARE	20
6.4 UPGRADING NAVIGATOR FIRMWARE AND SOFTWARE	21
6.5. NAVIGATOR REMOTE - CONTROL SCREENS	22
6.6 CREATING A NAVIGATOR NETWORK	24
Section Seven: Navigator Engineering Specifications	26
Section Eight: Cautions & Warranty	27

Section One: Introduction

Congratulations on your purchase of the Sabine Navigator. This product represents our latest breakthrough in our never-ending quest to improve the world's sound.

The Navigators come in three basic input/output configurations. The NAV3600 is a 3 by 6, the NAV4800 is a 4 by 8, and the NAV8800 is an 8 by 8. These System Processors are equally at home in both touring and installation applications, where they provide loudspeaker management, matrix mixing, and signal routing. State-of-the-art hardware and firmware guarantee superior sound quality and reliability.

All firmware and software can be upgraded using Sabine's Upgrade Wizard software, included on your Navigator CD.

Aside from the powerful array of features packed into a single unit (multiple crossovers, complete signal routing and mixing, FBX filters, parametric filters, high and low shelf filters, delay, compression, and limiting), the Navigator also offers a choice of user interfaces.

Computer control: When you install the included Navigator Remote Control Software you will see a very powerful yet simple user interface. All parameters and system status monitors are available without burying you in cryptic menus. From here you control all audio, security, linking, and file saving functions, and you can manage your entire network of Navigators.

Front Panel Control: The Navigator combines the best of both worlds. The front panel provides access to every audio and system function for each device. Gain control for each input and output is one touch away. LED signal meters for each input and output provide a clear picture of signal status, and editing is fast with the datawheel and cursor keys. Quickly control multiple channels simultaneously by pressing several channel buttons at the same time, which is very handy for those global changes.

Serial Remote Control Devices: Navigators are compatible with all the major serial controllers, including Crestron, AMX, and Cue.

Attractive wall-mounted switches for controlling presets, gain, muting, and other basic functions will be available from Sabine soon.

How to Use this Operating Guide

Detailed instructions are provided for all front panel controls, but you will probably be able to get going after taking a look at the Quick Start page. The instructions apply to all Navigators except where noted.

Later in this guide is an overview of installing and using the Navigator Remote Control Software. For more detailed information please see the Help section of the software.

If you have any questions you may call Sabine's Customer Service Department at 386-418-2000 from 9:30 am to 6:00 pm EST.

Section Two: Front & Back Panel Views

NAV3600 Front Panel

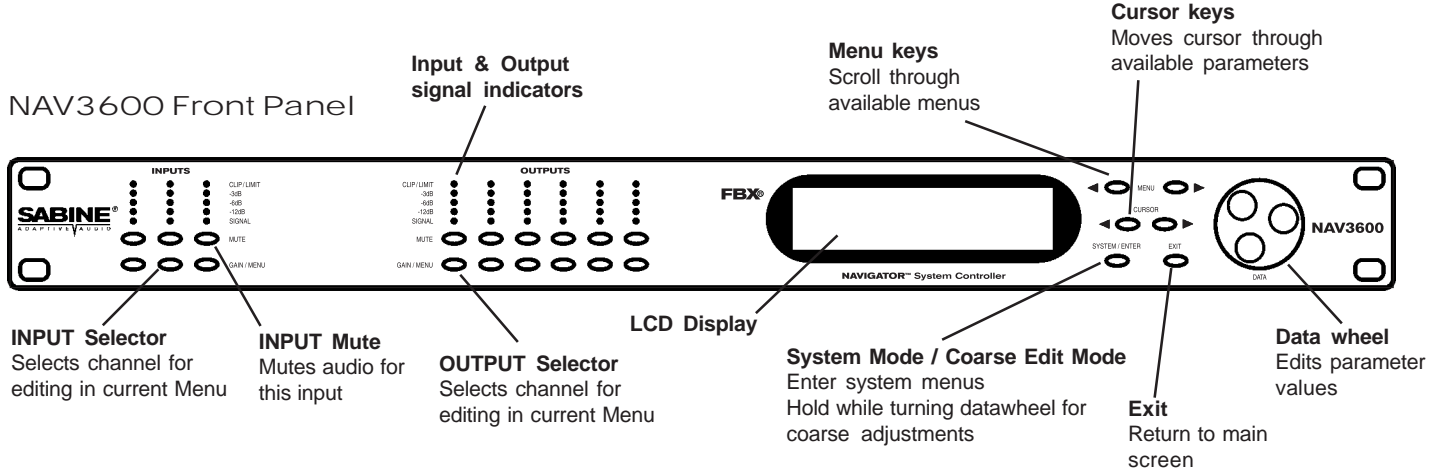

NAV3600 Back Panel

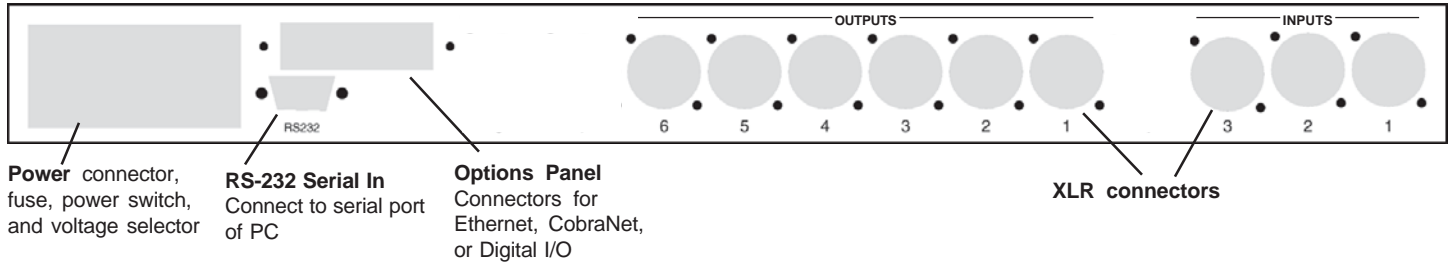

NAV4800 Front Panel

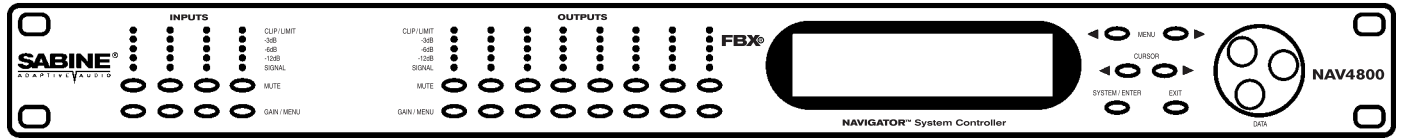

NAV4800 Back Panel

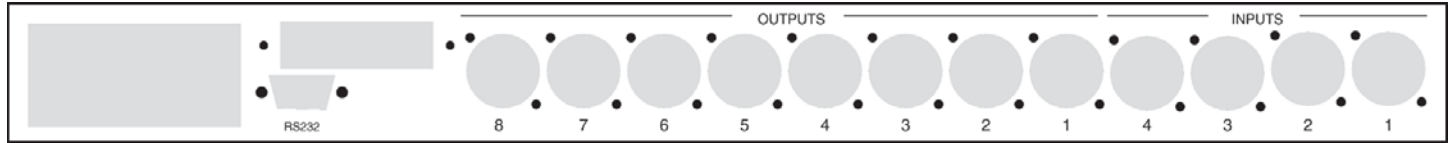

NAV8800 Front Panel

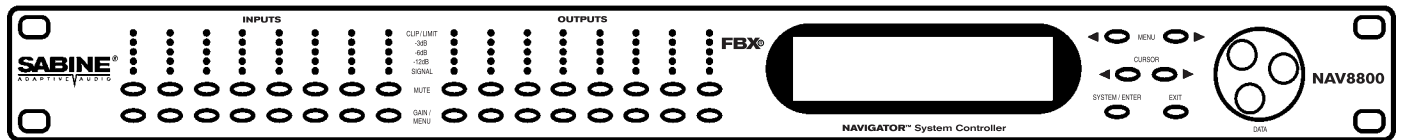

NAV8800 Back Panel

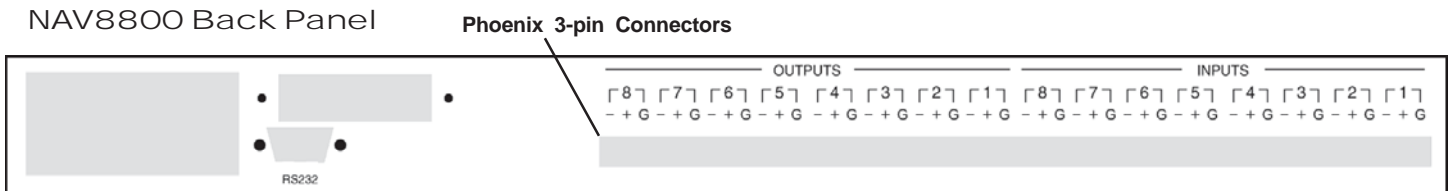

Section Three: Navigator Applications

3.1 INSTALLED AUDIO

House of Worship

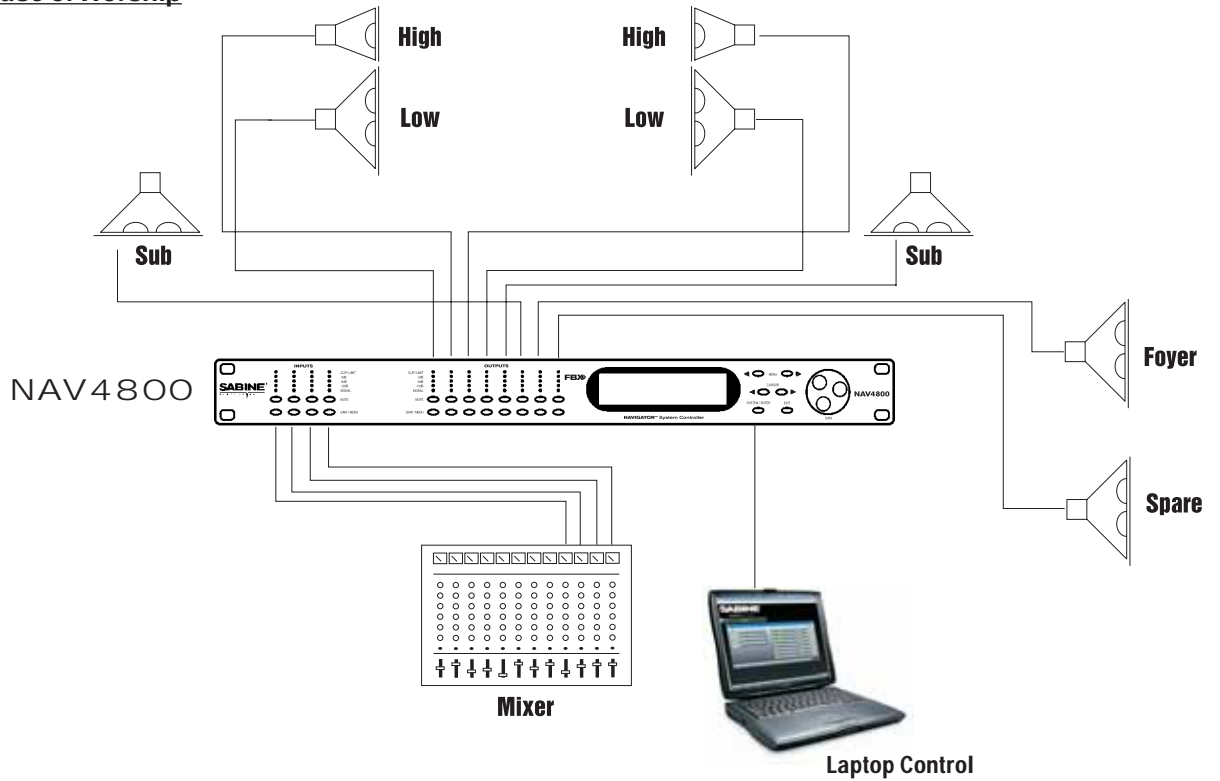

Conference Room - Distributed Audio

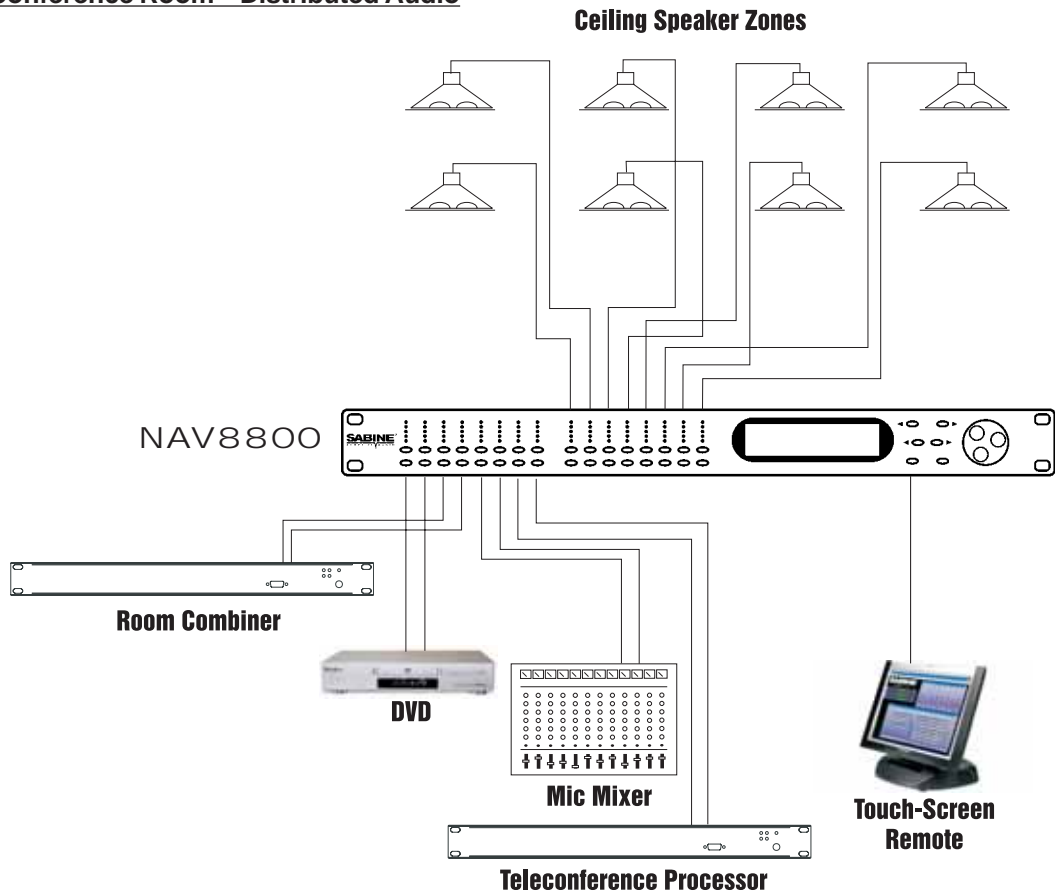

3.2 PRODUCTION AUDIO
Stereo 3-way, with Subs

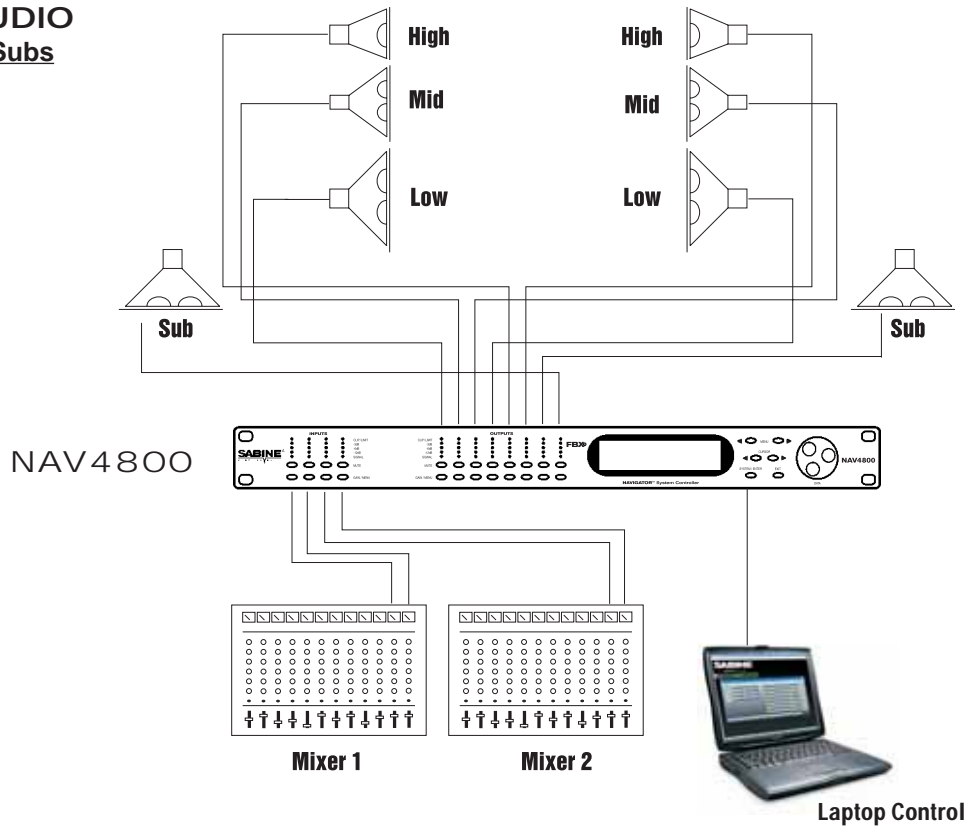

Left, Center, Right

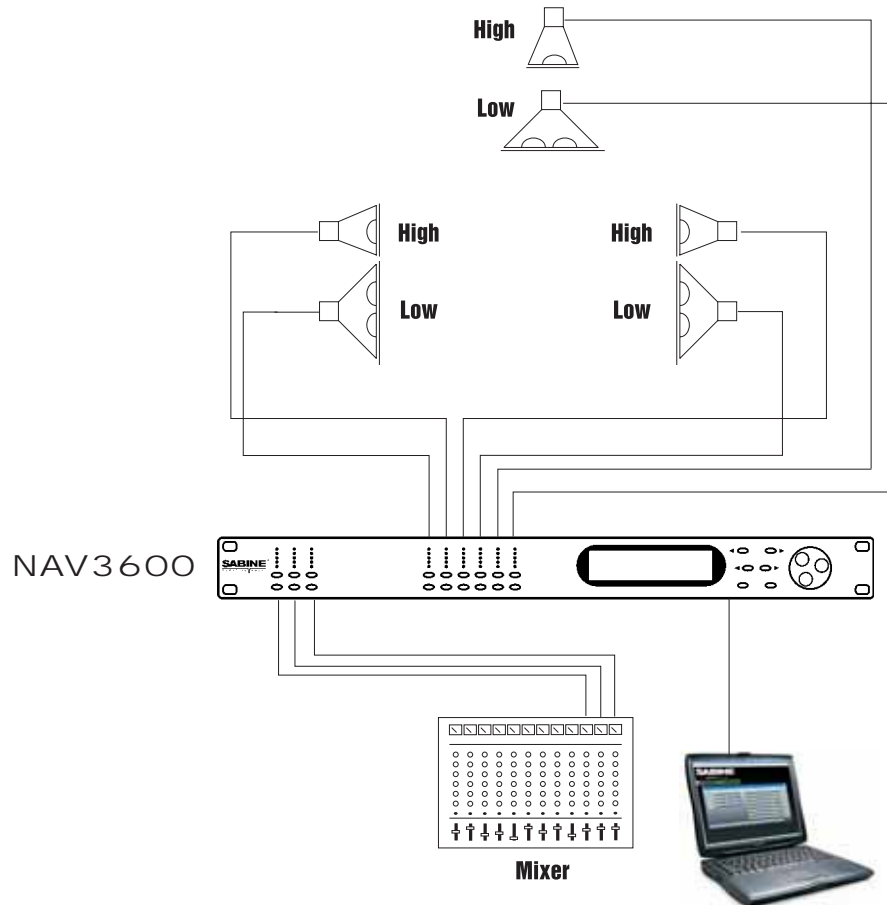

Section Four: Using Navigator Front Panel Controls

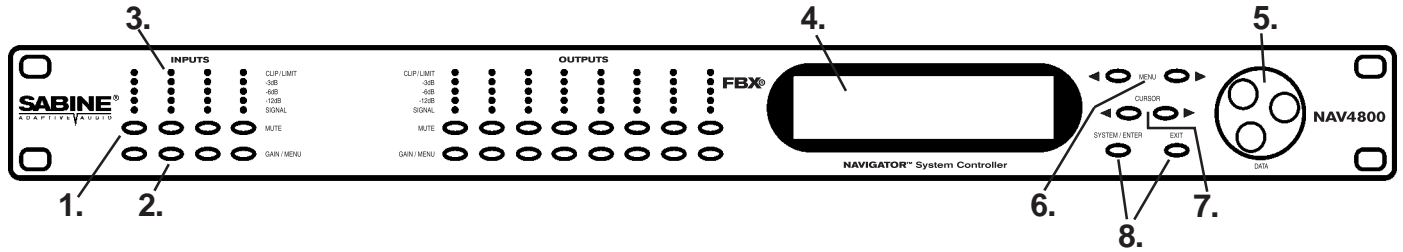

1. Mute keys - Mute/Unmute input and output channels. When an input channel is muted, the corresponding red LED will be lit.

2. Gain/Menu keys - Selects the corresponding channel for the LCD menu display indicated by a green LED. The last modified menu will be displayed on the LCD.

CHANNEL LINKING: Linking multiple channels is accomplished by pressing and holding one channel's menu key, then pushing the other desired channels. Or you can press and drag your finger across several channels. Linking is very powerful - it simplifies programming for common parameter values across multiple channels. Multiple inputs can be linked together and multiple outputs can be linked together. Inputs and Outputs are linked separately.

3. Peak Level LEDs - Indicates the current peak level of the Signal: Signal, -12dB, -6dB, -3dB, Clip/Limit. The Input **Clip** LED references to the device's maximum headroom. The Output **Limit** LED references to the threshold of the limiter.

4. LCD - Shows all the necessary information to control the unit.

5. Rotary Data Wheel - Changes parameter data values. The wheel has travel velocity sensing which allow for large incremental data modifications. For coarse modification of delay and frequency (1 Hz resolution) values, pressing the **Enter/Sys** key simultaneously will increment/decrement the data value by 100X.

6. Menu Control keys - The two Menu control keys move through the menus in a linear format.

- <<Menu: Previous menu screen
- Menu>>: Next menu screen

7. Cursor Control Keys - After choosing a menu to work with, use these keys to move around within each screen.

- <<Cursor: Previous cursor position in the menu screen
- Cursor>>: Next cursor position in the menu screen

8. Enter/Sys: Press this key to access the System Menu. These are the global parameters of the device. **Enter** is used only in the **System Menu** to proceed with selected actions, and in the FBX screen to initiate Setup mode.

Fast scrolling with the Enter/Sys key: Press this key while turning the data wheel to modify delay and frequency (1 Hz resolution mode) data values by 100X.

- Exit:** Exit to the **Main Menu**

TECHTIP

For fast scrolling of frequency or delay values, hold the Enter Key while turning the datawheel

4.1. QUICK START GUIDE TO THE NAVIGATOR FRONT PANEL

- After powering up the unit, the following initialization screen is displayed on the LCD:

```

***** SABINE NAV4800 *****
** NAVIGATOR CONTROLLER **
NAV4800 V4.03 11110000
-----INITIALIZING-----

```

- The initialization process takes about 8 seconds and during that period the unit boots and displays the Navigator firmware version.
- After the initialization process is finished the Navigator displays its main screen:

```

***** SABINE NAV4800 *****
** NAVIGATOR CONTROLLER **
DEVICE: _____
PROG:   _____

```

- The screen shows the current program number and program name assigned to the unit. The program assigned is always the last program the user recalled or stored before powering down the unit.

The Navigator is now ready to go.

4.1.1 Configuring The Navigator

Working with your Navigator is easy. Follow these basic steps to get started. For details on working within each menu, please read Section Five on operating the Navigator.

- 1. Signal Routing:** You first need to get your inputs routed to the appropriate outputs. You can do this in two ways.
 - A. Press Enter to enter the System Menu, press the >>Menu key until you get to the Configuration Menu, and choose one of the preset configurations. This is the fast way to get all your routing done.
 - B. Or you can press the green Menu key on one of the outputs, press the >>Menu until you get to the Source Menu, and choose which of the inputs you want to patch to this particular output.
- 2. Set Input/Output Gain:** The first menu you see when pressing the green Menu/Gain key on each input or output is the Signal Menu. The cursor is already in the Level field, and you can immediately turn the datawheel to adjust the input and output gain of each channel. This fast access to gain is very handy for quick adjustments during your program.
- 3. Mixing:** Mixing for each output is done in the Source Menu of each output (see 1.B. above). In this menu each input has a gain control so you can set the levels to create just the right mix in this particular output.
- 4. Crossover Filters:** At this point you may want to set the crossover filters for each of the outputs. You are essentially controlling which band of frequencies you will send to each of your speakers or speaker systems. Press the green menu key for the output you want to set, and press the Menu key until you get to the XOVER Menu. You will set filters for the lower and upper rolloff points, the slopes of the filters, and type of each filter.
- 5. Equalization:** You may want to adjust the frequency response of your system. The Navigator gives you a powerful set of EQ tools. For each input and output you can use up to six filters, and these can be either Parametric, High Shelving, or Low Shelving filters. Press the green Menu button on any input or output channel to access the EQ Menu.
- 6. FBX Feedback Exterminator:** Each input channel includes 8 patented FBX feedback control filters. Use the FBX Mode menu to begin Setup Mode for maximum gain before feedback. See the results of the process in the FBX Menu, and change the default FBX parameters on the FBX Global Menu.
- 7. Save your work:** You know how important this one is. If you are editing in the input/output menus, press Exit to get to the Main Menu. Then press Enter to get to the System Menus, and scroll to the Store Menu. Save and name your program here. Do it early and often!

Section Five: Operating the Navigator

5.1 INPUT MENUS

Each of the Navigator input channels has a separate **Menu** key. There are 7 function menus for each input channel, and you cycle through these by pressing the Menu keys. The first line in the LCD indicates which input channel you are editing, and shows the name of that channel if you have added one (for example, IN_1: _____), The menus are arranged in a linear fashion. Scroll to the right to reach the end, then scroll back to the left until you reach the beginning. Use the Cursor keys to select a parameter to edit, and use the Data Wheel to make your edits.

Signal

NAV4800 & NAV8800

IN_1: _____ MENU: Signal
 LEVEL: 0.00dB
 POL : +
 DELAY: 0 (000.000 ms)

NAV3600

I1: _____ Signal
 LEVEL: 0.00dB

- LEVEL: Gain, -40.00 dB to +15.00 dB in 0.25 dB steps.
- POL: Polarity, can be normal (+) or inverted (-).
- DELAY: Delay in 21 microsecond steps. Can be displayed in ms, ft or m. The time unit of the delay can be changed in the **System** menu. The maximum delay is 21,600 steps (450ms).

NAV3600

LCD Display has only 2 lines. Use Cursor key to access all parameters in each window

EQ

NAV4800 & NAV8800

IN_1: _____ MENU: EQ
 EQ#: 1 BW :0.33oct
 LEVEL: + 0.00dB Q=0.436
 FREQ : 1000Hz TYPE: PEQ

NAV3600

I1: _____ EQ1
 EQ#: 1

- EQ#: Selects one of the 6 available equalizer filters.
- LEVEL: Adjusts EQ level. Ranges from -30.00dB to +15.00dB in 0.25dB steps.
- FREQ: EQ center frequency. Ranges from 20 to 20,000 Hz in either 1 Hz steps or 1/36 octave steps. The frequency steps can be selected in the **System Menu**.
- BW: EQ Bandwidth. Ranges from 0.02 to 2.50 octaves in steps of 0.01 octave steps for PEQ. The Q value is automatically shown beneath the octave value. For Lo-Shf or Hi-Shf, it is either 6 or 12dB/Oct.
- Type: Type of EQ. The types can be PEQ (parametric), Lo-Shf (Low shelving), and Hi-Shf (High shelving).

FBX

See Section 5.6 for a complete description of how to operate the FBX Feedback Exterminator

FBX Feedback Exterminator

NAV4800 & NAV8800

IN_1: _____ MENU: FBX
 EQ#: 1 FREQ: 9020 Hz
 TYPE: FIXED (L) BW : 0.10 Oct
 LVL : -9dB

NAV3600

I1: _____ FBX1
 FBX#: 1

- EQ#: Selects one of the 8 available FBX filters.
- TYPE: Choose Fixed for gain before feedback, Dynamic for feedback control during the show. See section 5.5 for a complete guide to using the FBX function.
- LVL: Shows level in dB of the FBX filter (not editable).
- FREQ: Shows center frequency of the FBX filter (not editable).
- BW: Shows the width of the FBX filter (not editable).

FBX-Global Parameters

NAV4800 & NAV8800

IN_1: _____	MENU: FBX-Glob
LOCK : On	DEPTH: 24dB
BYPASS: On	WIDTH : 0.10
RSTDYN: Off	SENS: 3 PERS:3

NAV3600

I1: _____	FBXGbl
LOCK: On	

- LOCK: This refers to Fixed filters only, which by definition already are fixed in their centerpoint position. Locking prevents the filter from getting deeper. Locked is the recommended setting. Ready Mode automatically locks fixed filters.
- BYPASS: Bypasses all FBX filters on this Input channel. On indicates bypass; Off indicates FBX is active.
- RSTDYN: Reset Dynamic FBX filters. Turning to on toggles the reset function.
- DEPTH: Sets maximum depth of all FBX filters on this input channel. Range is 0 to -84dB.
- WIDTH: Sets default width of all FBX filters on this input channel. Range is 0.01 to 1.00 octave.
- SENS: Sets the Sensitivity of the FBX algorithm to the difference between music and feedback. Range is 1-5.
- PERS: Sets persistence - how long feedback can persist before a filter is set. Range is 1-5.
- Factory Defaults are recommended for Sensitivity, and Persistence settings.

FBX-Mode

NAV4800 & NAV8800

IN_1: _____	MENU: FBX-Mode
SETUP MODE	: Ready

NAV3600

I1: _____	FBXMod
SETUP MODE: Ready	

- SETUP MODE: On engages FBX Setup mode. Use this for setup only - not for use during the show. This step provides maximum gain before feedback. Follow on-screen instructions and raise gain slowly. **For a step-by-step guide to using the FBX see section 5.6.**

Compressor

NAV4800 & NAV8800

IN_1: _____	MENU: Compress
THRESH : 0.0dBu	
ATTACK : 10ms	RATIO: 2:1
RELEASE: 8x (80ms)	

NAV3600

I1: _____	Comp
TRESH: 0.00dBu	

- THRESH: Compressor Threshold. Ranges from -20 to +20dBu in 0.5dB steps.
- ATTACK: Attack time. Ranges from 0.3 to 1ms in 0.1ms steps; from 1 to 100ms in 1ms steps.
- RELEASE: Release time. Can be set at 2X, 4X, 8X, 16X or 32X the attack time.
- RATIO: Set compression ratio, 1:1 to 40:1 (Limit).

Channel Name

NAV4800 & NAV8800

IN_1: _____	MENU: Name
NAME: _____	

NAV3600

I1: _____	Name
NAME: _____	

- Name: Channel name. The maximum length is 6 characters. Use the datawheel to scroll through all the possible characters, and use the cursor keys to move to the next space. Once the name is created it will appear in the upper field of this window.

5.2 OUTPUT MENUS

Each output channel of the Navigator has a separate menu key. There are 6 menus for each output channel. The menus cycle in a linear fashion, just like the input menus. Use the Cursor keys to select a parameter to edit, and use the Data Wheel to make your edits.

Signal

NAV4800 & NAV8800

OUT_1: _____	MENU: Signal
LEVEL: 0.00dB	
POL : +	
DELAY: 0 (000.000 ms)	

NAV3600

O1: _____	Signal
LEVEL: 0.00dB	

NAV3600
LCD Display has only 2 lines. Use Cursor key to access all parameters in each window

- LEVEL: Gain, -40.00dB to +15.00dB in 0.25dB steps.
- POL: Polarity, can be normal (+) or inverted (-).
- DELAY: Delay is adjustable in 21 microsecond steps and displayed in ms, ft or m. The time unit of the delay can be changed in the **System** menu. The maximum available delay is 450ms.

EQ

NAV4800 & NAV8800

OUT_1: _____	MENU: EQ
EQ#: 1	BW :0.33oct
LEVEL: + 0.00dB	Q=0.436
FREQ : 1000Hz	TYPE: PEQ

NAV3600

O1: _____	EQ1
EQ#: 1	

- EQ#: Selects one of the 6 available Equalizer filters.
- LEVEL: EQ level. Ranges from -30.00dB to +15.00dB in 0.25dB steps.
- FREQ: EQ center frequency. Ranges from 20 to 20,000Hz in either 1Hz steps or 1/36 octave steps. The frequency steps can be selected in the **System Menu**.
- BW: EQ Bandwidth. Ranges from 0.02 to 2.50 octaves in steps of 0.01 octave steps for PEQ. The Q value is automatically shown beneath the octave value. For Lo-Shf or Hi-Shf, it is either 6 or 12dB/Oct.
- Type: Type of EQ. The types can be parametric (PEQ), Lo-Shf (Low shelving), and Hi-Shf (High shelving).

Crossover



NAV4800 & NAV8800

OUT_1: _____	MENU: XOver
FTRL: Off	FTRH: Off
FRQL: 1000Hz	FRQH:1000Hz
SLPL : 24dB	SLPH:24dB

NAV3600

O1: _____ XOver
FTRL: Off

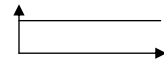
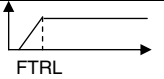
- FTRL: Choose the type of low frequency filter (high pass). Types can be Butterworth (Butterworth), Link-Ri (Linkwitz-Riley) or Bessel.
- FRQL: Filter cut-off frequency of low frequency crossover point (high pass). Ranges from 20 to 20,000Hz in either 1Hz steps or 1/36 octave steps. Select frequency resolution in the **System Menu**.
- SLPL: Filter Slope of low frequency crossover point (high pass). Ranges from 6 to 48dB/octave in 6dB/octave steps. If the selected Filter Type is Linkwitz Riley, the available slopes are 12 / 24 / 36 / 48 dB/octave.
- FTRH: Choose the type of high frequency filter (low pass). Types can be Butterworth (Butterworth), Link-Ri (Linkwitz-Riley) or Bessel..
- FRQH: Filter cut-off frequency of high frequency crossover point (low pass). Ranges from 20 to 20,000Hz in either 1Hz steps or 1/36 octave steps. Select frequency resolution in the **System Menu**.
- SLPH: Filter Slope of high frequency crossover point (low pass). Ranges from 6 to 48dB/octave in 6dB/octave steps. If the selected Filter Type is Linkwitz Riley, the available slopes are 12 / 24 / 36 / 48 dB/octave.

Filter Configuration	Low crossover point (FTRL)	High crossover point (FTRH)	
None	Off	Off	
Highpass	NOT Off	Off	
Lowpass	Off	NOT Off	
Bandpass	NOT Off	NOT Off	

Compressor

NAV4800 & NAV8800

OUT_1: _____	MENU: Compress
THRESH : 0.0dBu	
ATTACK : 10ms	RATIO: 2:1
RELEASE: 8x (80ms)	

NAV3600

O1: _____ Comp
THRESH: 0.00dBu

- THRESH: Compressor Threshold. Ranges from -20 to +20dBu in 0.5dB steps.
- ATTACK: Attack time. Ranges from 0.3 to 1ms in 0.1ms steps; from 1 to 100ms in 1ms steps.
- RELEASE: Release time. Can be set at 2X, 4X, 8X, 16X or 32X the attack time.
- RATIO: Set compression ratio, 1:1 to 40:1 (Limit).

Input Source

NAV4800 & NAV8800

OUT_1: _____	MENU: Source
In1: On _____	In4: Off
In2: Off	
In3: Off	

NAV3600

O1: _____	Source
In1: 0.00	

· 1, 2, 3, 4 – Input channel source for the current output channel. This is your sub-mixer for each output of the Navigator. Values range from 0.00 (Maximum level) to -40, then OFF, which mutes that input for the output you are editing.

NAV3600
LCD Display has only 2 lines. Use Cursor key to access all parameters in each window

Channel Name

NAV4800 & NAV8800

OUT_1: _____	MENU: Name
NAME: _____	

NAV3600

O1: _____	Name
NAME: _____	

· Refer to the Input Menus for details.

5.3 SYSTEM MENUS

The **System Menus** allow you to control and change global parameters that are related to the general operation of the Navigator. Press EXIT to access the Main Menu, then SYSTEM to enter the System Menus. All System Menu require the Enter key to be pressed to confirm the selected action.

Program Recall

The Navigator has a built in non-volatile memory that can store up to 30 different program setups. A program can be recalled using this menu.

NAV4800 & NAV8800

SYSTEM-SETUP	MENU: Recall
PROG: 1	
NAME: _____	

NAV3600

SYSTEM	Recall
P:1 _____	

- PROG: Program Number to be recalled..
- NAME: Program Name of the program. This is read only; names can be changed in the Store menu.

Program Store

The Navigator has a built in non-volatile memory that can store up to 30 different program setups. A program can be stored using this menu. The old program with the same program number will be replaced. Once the program is stored in the flash memory, it can be recalled at a later time, even after power down.

NAV4800 & NAV8800

SYSTEM-SETUP	MENU: Store
PROG: 1	
NAME: _____	

NAV3600

SYSTEM	Store
P:1	

- PROG: Program Number for the current data to be stored.
- NAME: Program Name, allows a maximum length of 12 characters.

Configuration

NAV4800 & NAV8800

SYSTEM-SETUP MENU: Config
MODE: None

NAV3600

SYSTEM Config
MODE: None

· MODE - configures the mode of operation.

Mode:	Out 1	Out 2	Out 3	Out 4	Out 5	Out 6	Out 7	Out 8
None	Any	Any	Any	Any	Any	Any	Any	Any
Stereo 2-Way	In1	In1	In2	In2	Any	Any	Any	Any
Stereo 3-Way	In1	In1	In1	In2	In2	In2	Any	Any
Stereo 4-Way	In1	In1	In1	In1	In2	In2	In2	In2

The unit assigns the Input source for the corresponding outputs when the Mode of Configuration is selected. The crossover point parameters like the filter type, cut-off frequency and slope have to be configured manually in the **Xover** Menu in each Output menu.

*Note: The configuration mode configures the input sources when selected. The user can change the source afterwards if desired. It does not keep the configuration in memory.

Copy Parameters

NAV4800 & NAV8800

SYSTEM-SETUP MENU: Copy
SOURCE: In1
TARGET : In1

NAV3600

SYSTEM Copy
SOURCE: In1

Copy channel parameters from the source to the target. When the Source and Targets are both Inputs or Outputs, all audio parameters will be copied. When one of the Source or the Target is an input while the other is an output, only the Level, Polarity, Delay and EQ are copied.

- SOURCE: Channel to be copied from.
- TARGET: Channel to be copied to.

General System Parameters

NAV4800 & NAV8800

SYSTEM-SETUP MENU: General
FREQ MODE : 36 Steps/Oct
DELAY UNIT : ms
DEVICE# : 1 PORT:RS232

NAV3600

SYSTEM General
FREQ MODE: 36/Oct

- FREQ MODE: Selects the frequency control mode for EQ and crossover filters. Can be 36 steps/octave or All Frequencies (1 Hz resolution).
- DELAY UNIT: ms, ft or m.
- DEVICE#: Assigns the device ID from 1 to 16. This ID is useful when a network of more than 1 unit is present.
- PORT: Choose control port. RS232 for direct connection to a computer, or CAT-5 for Ethernet.

Security

The Navigator enables the user to secure the unit and prevent undesired changes in the setup. In order to make changes to the security levels the user must enter the correct password.

NAV4800 & NAV8800

SYSTEM-SETUP MENU: Security
 MENU : In-Signal
 LOCK : No
 PASSWORD: _____

NAV3600

SYSTEM Secure
 PASSWORD: _____

NAV3600
 LCD Display has only 2 lines. Use Cursor key to access all parameters in each window

· MENU - Selects the menu to be locked/unlocked. The options are:

- In-Signal: Input Signal Menu (Level, Polarity, Delay).
- In-EQ: Input EQ Menu.
- In-Name: Input Channel Name Menu
- Out-Signal: Output Signal Menu (Level, Polarity, Delay).
- Out-EQ: Output EQ Menu.
- Out-Xover: Output Crossover Menu.
- Out-Limit: Output Limit Menu.
- Out-Source: Output Source Menu.
- Out-Name: Output Channel Name Menu.
- System: System Menu

· LOCK: Engages lock (Yes) or unlock (No) for the corresponding menu.

· PASSWORD: Enter your 4-character password here. Initial password creation must be done within Navigator Remote Software. Entering the same password here initiates the lockout function. Press Enter and your Navigator front panel controls will be locked according to the menu selections you made. You can alter those selections via the front panel or through the software.

5.4 INPUT/OUTPUT REFERENCE GUIDE

This chart shows all the parameters and edit values for each control on each menu. Use this as your reference for ranges of all parameters in each menu.

Parameters	<<Menu>>	<<Cursor>>	Min	Max	Steps	Units
Level	Signal	LEVEL	-40	15	0.25	dB
Polarity	Signal	POL	+ / -			
Delay	Signal	DELAY	0	21,600	1	21us steps
EQ Number	EQ	EQ#	1	6	1	
EQ Level	EQ	LEVEL	-30	15	0.25	dB
EQ Frequency	EQ	FREQ	20	20,000	1	Hz
EQ Bandwidth	EQ	BW	0.02	2.5	0.01	Octave
Crossover Low	XOver	FTRL	Off / Butterworth / Linkwitz-Riley / Bessel			
Crossover Low	XOver	FRQL	20	20,000	1	Hz
Crossover Low	XOver	SLPL	6	48	6	dB/octave
Crossover High	XOver	FTRH	Off / Butterworth / Linkwitz-Riley / Bessel			
Crossover High	XOver	FRQH	20	20,000	1	Hz
Crossover High	XOver	SLPH	6	48	6	dB/octave
Limiter Threshold	Limit	THRESH	-20	20	0.5	dBu
Limiter Attack	Limit	ATTACK	0.3	100	0.1/1	ms
Limiter Release	Limit	RELEASE	2 / 4 / 8 / 16 / 32X Attack time			
Source Select	Source	1, 2, 3, 4	Off / On			
Channel Name	Ch-Name	NAME	6 characters			

5.5. FEEDBACK CONTROL AND PARAMETRIC EQUALIZATION

Operation of the FBX Feedback Exterminator section of the front panel of your Navigator is simple, but may require a brief explanation for those of you unfamiliar with Sabine FBX products and/or terminology. Let's begin by defining a few key terms.

5.4.1. Glossary of Terms

- **FEEDBACK** describes what happens when a loudspeaker disperses sound back into an amplified microphone, at a level sufficient to allow one or more frequencies to ring out of control. Feedback can occur at any frequency, but is especially painful at mid to high frequencies. The specific frequencies that feedback in a particular situation depend on the acoustics of the environment, the placement of the microphone(s) and speaker(s), the response characteristics of the sound system components, and the volume of amplification. Anyone who has operated a sound system or attended a conference or a concert is familiar with feedback and its unpleasant consequences!
- A **PARAMETRIC EQUALIZER** allows the user to precisely specify three critical values that determine an equalizer's characteristics: the center frequency of the EQ band that is boosted or cut (measured in Hertz), the amount of boost or cut imposed at the center point (measured in dB), and the width of the bell-curve shaped frequency band that is affected (typically measured in octaves).
- An **FBX FILTER** is essentially an automatically placed, narrowly attenuated parametric filter, with the center point of its narrow cut tuned to a precise frequency that feeds back when a sound system amplifies one or more microphones to a sufficient volume. The Navigator will automatically place up to 8 FBX filters in the signal path, corresponding to 8 distinct frequencies of feedback.
- A **FIXED FBX FILTER** will not move from the original set frequency of the filter. Once it sets itself, it remains at the same frequency. The system's gain before feedback is limited primarily by the number of fixed filters; i.e., increasing the number of fixed filters increases the system's gain before feedback. However, unless it is **LOCKED**, a **FIXED FILTER** may move its notch deeper without changing frequency. Fixed filters are typically set by turning up system gain to the point of feedback prior to sound check or performance, and they represent the "first layer" of feedback protection.
- A **DYNAMIC FBX FILTER** acts like a Fixed filter, until all available FBX filters (Fixed or Dynamic) are in use and a new frequency begins to feedback. When this happens, whichever Dynamic filter was set earliest in the performance will drop its original frequency and move to the new one. Dynamic filters are especially useful with mobile or wireless microphones (where feedback frequencies may change due to microphone repositioning) and represent the "second layer" of feedback protection. Note that both Fixed and Dynamic filters can be set while music is playing (except when in Setup Mode). One of the distinguishing properties of the Sabine FBX algorithm is its ability to distinguish music (or speech, or other sounds) from feedback.
- A **LOCKED FBX FILTER** is a Fixed filter locked in place; i.e., it cannot get any deeper or change its frequency. Locked fixed filters are no longer adaptive. Locking Fixed filters ensures your first layer of feedback protection is always in place -- highly recommended.
- **FILTER WIDTH** generally refers to the width (measured in octaves, or fractions thereof) of a filter, including graphic EQ filters, parametric filters, and FBX filters. More specifically, width is defined by determining the outer frequencies (surrounding the filter center point) that are altered ± 3 dB when the filter is imposed.
- **CONSTANT Q** filters are filters whose widths remain constant regardless of the amount of boost or attenuation imposed by the filters. Some EQ units on the market are Constant Q; others are Proportional Q, meaning the filter gets wider as it gets deeper. All Sabine products use Constant Q filters, to prevent affecting any more sound than necessary.
- **FBX Setup Mode** refers to Sabine's exceptionally fast method of placing FBX filters during sound system setup. Think of Setup mode as your key to achieving one of the main benefits of the FBX: getting more gain before feedback. In Setup the FBX is very sensitive so **do not talk into the mics during setup**, and try to keep room noise to a minimum. Setup is designed to allow feedback to occur at lower input levels, and it imposes a strong limiter on the feedback output as it occurs. The net result is that you are able to ring out feedback more quickly, and at a much quieter level!

NOTE: MAKE SURE Setup Mode IS OFF and Ready Mode IS ENGAGED WHEN YOU USE THE NAVIGATOR OR YOUR AUDIO SIGNAL QUALITY MAY SUFFER!

5.6. FBX OPERATING INSTRUCTIONS

Follow these steps to obtain the maximum gain before feedback, with minimal or no loss in the tonal quality of your program. You should always setup one channel at a time by turning down the other channels of the mixer or power amplifiers.

STEP ONE: EQUIPMENT SETUP

Set up your sound system and position all the speakers and microphones you anticipate using. When possible, avoid placing microphones directly in front of speakers. Patch the Navigator into the system (refer to section Three for installation configurations). Set your levels for nominal performance but avoid raising the gain enough to induce feedback. If you are using a graphic EQ, adjust only for the desired tonal qualities, but **DO NOT NOTCH FOR FEEDBACK**. If there is any equipment in the signal path that incorporates a noise gate function, you **MUST DISENGAGE** these noise gates prior to the setup procedure. You may reengage them upon setup conclusion. For best results setup your FBX on one input channel at a time. You can mute the audio in the other input channels.

STEP TWO: CHOOSE YOUR FILTER TYPES and REMOVE BYPASS

The default filter setting for your Navigator are 6 FBX Fixed Filters and 2 FBX Dynamic Filters per input channel. You may change that mix of filters, and this should be done before you enter Setup Mode. You can always alter the mix of FBX filters and repeat the Setup procedure. To change filter types, choose the FBX Menu in the Input Channel you are working on.

The factory default for the FBX is BYPASS: On, which means the FBX section is Bypassed. Before you start FBX Setup, select the input channel you are working on, then go to the FBX Global Menu. Set the BYPASS to Off, meaning the FBX section is now active.

FBX Bypass

Be sure and take the FBX section out of Bypass before setup! Do this in the FBX Global Menu.

STEP THREE: ENGAGE SETUP MODE - RESET FILTERS

Choose an input channel and select the FBX-Mode Menu. Using the datawheel select "Setup" in the SETUP MODE field, then press ENTER. Press ENTER again to confirm Setup Mode. **Setup mode clears all Fixed & Dynamic filters. Do not use Setup mode during your performance.**

```
IN_1: _____ MENU: FBX-Mode
SETUP MODE : Setup
```

Press <Enter> to Proceed

*Press enter to begin Setup -
NAV4800 (above), NAV3600 (below)*

```
*****SETTING UP FBX*****
      Quiet Please
      Raise Gain Slowly
      Press <Exit> to End
```

*Raise gain slowly; Setup automatically ends
or got to Ready mode any time by pressing
Exit - NAV4800 (above), NAV3600 (below)*

NAV3600

LCD Display has only 2 lines. Use Cursor key to access all parameters in each window

```
I1: _____ FBXMod
Setup?: <Enter>
```

```
FBX SETUP MODE
Abort: <Exit>
```

STEP FOUR: RAISE MASTER GAIN

Make sure your power amplifier is turned up and your microphones are turned on. Slowly raise the master gain of your mixer (or the submix for this input channel of the Navigator) until the first feedback begins. The FBX will quickly remove the feedback by setting the first filter. Continue to raise the gain slowly. Try to avoid making two or more frequencies feed back at the same time, which sometimes happens if the gain is raised too quickly. As new frequencies feed back, new filters will be placed. (Note: sometimes the same frequency will feed back a second time, and an earlier filter will notch more deeply.)

Continue raising the gain. Setup mode will end and Ready mode will be engaged in one of two ways:

1. All of the Fixed filters and at least the first Dynamic filter are set. This will automatically turn **Setup Mode** off and the FBX Menu window will be displayed. At this point **STOP RAISING THE GAIN!**

2. You've set as many filters as you need or want, even though you haven't used them all. Press EXIT to prevent any more Fixed filters from setting, or any of the set Fixed filters from notching more deeply. Pressing EXIT exits **Setup Mode** and the FBX Menu window will be displayed.

You are now ready to begin your program!

IN_1: _____	MENU: FBX
EQ#: 1	FREQ: 9020 Hz
TYPE: FIXED (L)	BW : 0.10 Oct
LVL : -9dB	

See the results: In the FBX Menu you can view the parameters of all your FBX Filters. Scroll through all the filters in the FBX# field. You may edit the type of filter, but not the level (LVL), width (BW), or frequency (FREQ). You may want to create parametric filters based on the results of your FBX Setup, then repeat the Setup procedure to maximize system gain.

5.6.1. FBX Setup Mode Cautions & Alternate Setup Procedure

Setup Mode is designed to allow fast and quiet feedback elimination during setup. Setup Mode should ONLY be used for pre-performance setup. **DO NOT USE Setup Mode DURING A PERFORMANCE!** This will produce distorted audio and set filters on music or audio program. Setup Mode also may not work well during setup in a very noisy environment. To speed up feedback elimination, Setup relaxes the FBX criteria for distinguishing "good" audio from feedback and places filters more readily. If the environment is noisy, there is a greater likelihood of placing a filter on audio that is not feedback.

If you are working in a noisy environment you can still get the benefit of the Setup procedure, which is more gain before feedback. Instead of Starting in the FBX Mode Menu, begin in the FBX Global Menu. This procedure will still eliminate feedback very quickly, though not as quickly as Setup Mode, and without reducing the volume of the feedback before it is filtered out.

1. Change the LOCK setting to Off. Now the Fixed filters are available to react to feedback.
2. Follow Step Four of the Setup procedure outlined above -- raise the gain for this input channel.
3. Continue raising the gain until you achieve the gain before feedback you require, or you set all the fixed filters. You can see the results of this procedure in the FBX Menu (shown above).
4. **VERY IMPORTANT:** Go back to the FBX Global Menu and set LOCK to On. This will lock the fixed filters and prevent them from going any deeper. If you use the factory default settings you will still have two dynamic filters available for automatic feedback control during the program.

Whether or not Setup Mode is used, the end result of setting up FBX filters should be identical. Your sound system will have clearer, louder, feedback-free sound.

5.6.2. FBX Feedback Exterminator - Global Parameters

A unique feature of the FBX Feedback Exterminator is the ability to adjust the way the algorithm reacts to feedback. Unlike other feedback controllers, you can create and save your own customized versions of the FBX.

See section **5.1 Input Menus** for instructions on using the Global parameters of the FBX.

Sensitivity and **Persistence** are controls that allow the speed and analysis of the FBX algorithm to match the type of audio program. Some audio programs, notably certain types of classical music, produce occasional waveforms that are difficult to distinguish from acoustic feedback. The factory default Sensitivity and Persistence values should work in almost all conditions; however, you may change them if necessary to prevent the possibility of triggering a false filter, or to more quickly set the FBX filters. There is a trade-off between speed of filter placement and how carefully the filter is placed. More demanding audio sources (that is, program material with musical content that is similar to feedback, like flutes and organs) may require higher Sensitivity & Persistence settings, which will slightly slow down the speed of filter placement, but decrease any possibility of mistaking program audio for feedback. Lower settings are recommended when you need faster reaction during speech-only programs.

Section Six: Using Navigator Remote Software

The Navigators are designed with easy-to-use front panel controls. You can experience the full capability of the Navigator by using the Navigator Remote Software, which opens up a whole new level of programmability. With the software you get increased storage capacity -- save an unlimited number of programs as files, transfer files from one unit to another, and download and upload an entire set of programs to your Navigator. You can also view and edit every function very quickly and arrange various functions on screen to suit your needs. These setups or screensets can be saved and recalled.

All Navigator models come equipped with the hardware and software necessary to run the units via remote control from a Windows-equipped computer. Your unit should include one CD ROM that includes the Navigator Software and the Navigator Upgrade Wizard for future upgrades of your firmware.

6.1. SYSTEM REQUIREMENTS AND RECOMMENDATIONS

1. PC computer equipped with Pentium processor 100 MHz or faster and hard disc with at least 5 MB of available space for program files.
2. Windows 2000 or higher and SVGA or greater resolution graphic card and monitor.
3. One COM port for RS232 serial connection, with a 16550 or faster COM chip.

6.2. CONNECTIONS

If your computer has a 9-pin COM port, use a standard 9-pin male to standard 9-pin female RS-232 connector, available from most computer stores (for connecting multiple Navigators you will need to have the -EN version which includes the built-in Ethernet interface for use with a network switch/hub). Connect the computer's COM port to the back of the Navigator RS-232 jack labeled SERIAL. **Do not use any connectors that are wired for a null modem.**

Connection via USB port requires a USB to RS-232 9-pin adapter. These devices vary widely in their compatibility with serial devices. Check our web site for a current list of adaptors tested by Sabine. We offer one of these that is tested and approved for use. The Sabine part number is USB-RS232.

If you have successfully, or unsuccessfully tried a different USB to RS-232 adapter, please contact Sabine so we can maintain and a shared list of adaptors that are known to work with Sabine products.

6.3. INSTALLING AND USING THE SOFTWARE

Follow the on screen instructions for installing the Sabine Remote Control Software for the Navigator. If you are using the Navigator in network (-EN versions) see Section 6.6 for details.

After the installation you should have a Navigator software icon on your desktop. We also suggest you install the Navigator Upgrade Wizard software. This will come in handy when you want to upgrade the firmware in your Navigator.

TECH TIP

PC can't find Navigator

Try these tips if you are having difficulty connecting your Navigator unit(s) to a Windows PC.

1. **Software Version.** Make sure the software version installed in your computer is compatible with the firmware version of your Navigator
2. **Check cable.** You want a serial 9-pin, not a null modem.
3. **COM Port.** Make sure the COM Port selected is correct. If not you may get an "Invalid Port" message when running the software. Click OK and then correct the port setting.
4. **Refresh your COM Ports.**
In Windows, click **Start** and select **Settings, Control Panel**, then double click **System**. Click on **Hardware, Device Manager** and open up **Ports (COM & LPT)**. Right click the **COM Port** for your Navigator and select **Remove** (or **Uninstall**). Your computer will verify your intent and then reboot. As it reboots, it will rebuild your COM Port file. This will clean out previous settings for devices no longer attached to your computer and may allow the Navigator software to locate your unit(s).
5. You may be prompted for a **log-on password** even though you have not assigned one. This message can also indicate you are having trouble connecting. Check items 1-4 in this list to get connected.

NOTE: **COM Port Properties & Settings** (Bits per second, Data bits, Parity, Stop bits & Flow control) are controlled by the Navigator Software and need not be adjusted.

Instructions for connecting to your Navigator are shown below. If you have any trouble with your connections please refer to the Tech Tip on the previous page.

USB-RS232

When installing the driver for a USB to RS232 convertor you must find out which Com port your computer assigned to that device. Follow the procedure in the previous Tech Tip to find the port number in the Device Manager on your computer (do not uninstall it!). Set the Com port on the Navigator software to match that number.

Connecting to your Navigator:

1. Patch the serial connection to your computer using a standard 9-pin RS232 serial cable or a USB to RS232 convertor and run the Navigator Software.
2. Choose Connection on the main screen. Here you will choose the mode (Live for connecting to the Navigator, Design for offline editing) and the connection (RS232 or Ethernet [-EN versions only]).
3. Choose your comm port or IP numbers for the device number you are using (device numbers can be changed in the Navigator unit in the **System-Setup: General** menu on the front panel). For connecting to one Navigator click on Live Mode, select Device 1, and select RS232. For more about connecting to a Navigator Network, see section 6.6.
4. With the proper com port (or IP numbers) selected to which you patched your Navigator (usually com 1 or 2) and click the OK button. **Your unit is connected when the green status display in the lower right of the main screen shows "Link: OK."**
5. If you have any trouble connecting, see the Tech Tip on this and the previous page.

Once you are connected you can proceed to use all the powerful features of the Navigator. For a basic explanation of all controls on the main screen, please see the following page.

A word about Navigator file types

Using your computer as a platform gives you unlimited memory storage of Navigator files. There are **three types of files** associated with the Navigator:

XDT files: These files are the equivalent of one of the 30 programs that can be stored within the Navigator. All parameters for one Navigator are stored in a .XDT file. You can store as many of these as you need on your PC. These are accessed using the **Open File** or **Save File** buttons in Navigator software. To store your work directly in the Navigator as a program, choose **Store Prog** or **Recall Prog**.

XLT files: These files store a listing of 30 Navigator programs. Store and recall these using the Download function in Navigator software. Think of these files as a way to store all 30 programs of a Navigator in one place. This can be handy if you need to make a backup of everything stored within the Navigator. Or you may want to categorize your programs according to applications. These can be downloaded to the Navigator all at once using XLT files. Use the upload function to move the 30 programs from the Navigator to your PC. The default location for these files is the Sabine/Navigator directory on your PC.

XST files: These files are for storing and recalling all parameters not directly associated with Navigator functions. Links, window positions, and network information is stored in an XST file. Access these using Open Setup or Save Setup. The most common use for this file type is to save all the IP information when you create a Navigator Network (-EN versions only).

6.4 UPGRADING NAVIGATOR FIRMWARE AND SOFTWARE

Firmware is the internal operating system of your Navigator unit. Software is the program you install on your computer to control the Navigator. Your Navigator CD includes the **Navigator Upgrade Wizard** program. You will use this program to upgrade the firmware in your unit. You may choose to do this in order to get any recent improvements or added features.

Here is the procedure for upgrading your firmware.

1. Use your browser and visit www.Sabine.com. Click to the Navigator page (Professional Audio section) and download the latest firmware. You can save the file anywhere on your computer, but make a note of it!
2. Run the Navigator Upgrade Wizard and follow the on-screen instructions. You will be asked to choose the firmware file, and here you will point to the file you downloaded from Sabine.com.
3. Continue with the on-screen instructions and you will complete the firmware upgrade.

6.5. NAVIGATOR REMOTE - CONTROL SCREENS

**Guide to Main Screen Controls:**

- **File** (New, Open Save): Files (.xdt) are used to store and recall parameters of the Navigator on your computer. Equivalent to Programs, which are stored in the Navigator.
- **Program** (Recall, Store): These live within the Navigator's on-board memory. Equivalent to Files on your computer.
- **Download, Upload**: All programs stored within your Navigator can be transferred to (Download [.xlt files]) and from (Upload) your computer using this function. Handy for loading a whole set of programs into the Navigator.
- **Device**: Choose which type of Navigator you are programming in Design (offline) Mode.
- **Security**: Select which control menus will be locked when you set a password on the Navigator. Passwords are set in this window only.
- **View Data**: Displays the values for every parameter in the Navigator. You can print the data from here, too.
- **Connection**: Connect to the Navigator via RS232 or, with -EN versions, via Ethernet.
- **Setup** (New, Open, Save): Think of Setups as your screen sets and network settings. Custom desktop arrangements can be saved and recalled. Links between units are also saved in Setups (.xst files).
- **Link**: This window allows you to set your function links between networked Navigators.
- **Copy**: Use this window to copy selected settings to all the Navigator (-EN) devices in your network.
- **Preferences**: Set the way the Navigator displays various units of measure.

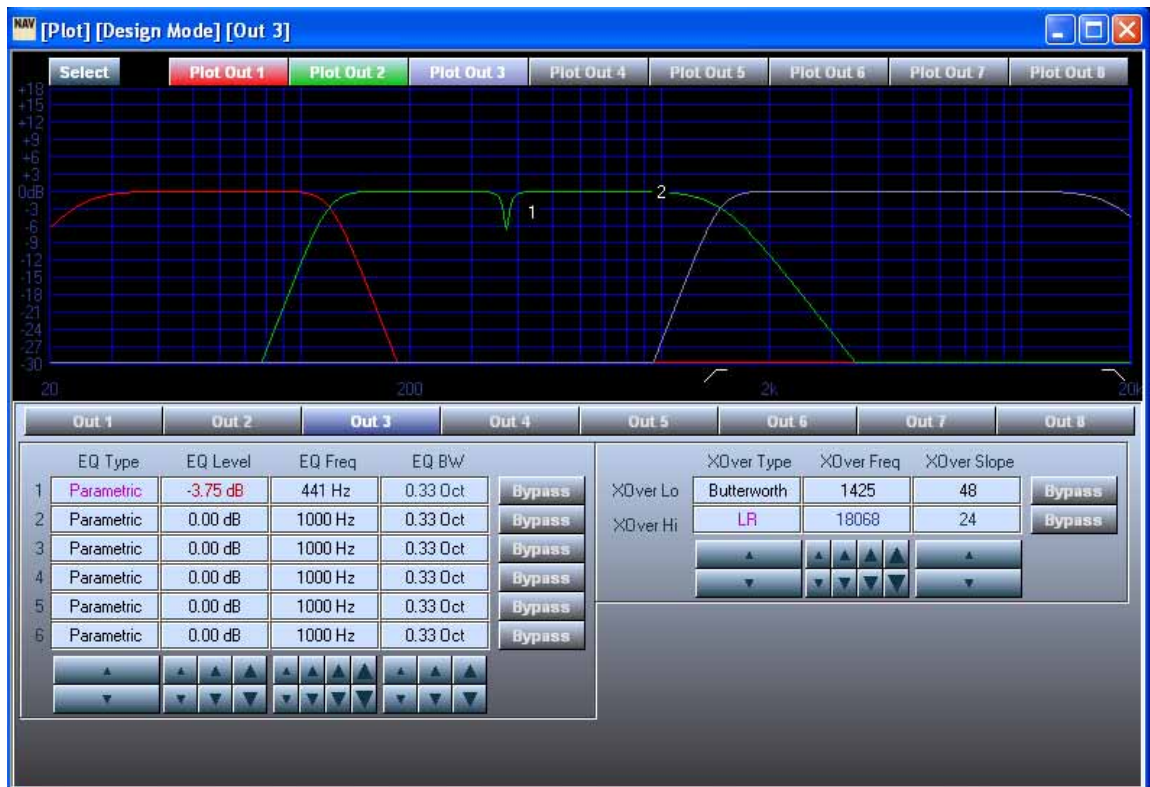

Guide to Crossover Screen Controls:

- **Select/Single:** This button toggles your view of the output response curves of your Navigator. Choosing Select allows you to see multiple curves on the same screen. Choose Single if you only want to see the output selected for editing.
- **Plot 1-8 Out:** When in Select mode (as described above) these buttons allow you to choose which output curves will be displayed in the response curve window.
- **Out 1-8:** These buttons select which output you are editing. All controls on the lower half of the screen, and all graphic editing is done on the selected output. Select Output first!
- **EQ Type:** Choose between Parametric, Low Shelf, and High Shelf using the arrows at the bottom of this column. You must choose a type before any editing.
- **EQ Level:** Set levels using the arrows at the bottom of the column (note the three sizes for coarse or fine adjustments) or you can edit the filter level graphically by using your mouse and grabbing the filter number.
- **EQ Freq.:** Set filter center points using the arrows at the bottom of the column (note the three sizes for coarse or fine adjustments) or you can edit the filter frequency graphically by using your mouse and grabbing the filter number.
- **EQ BW:** Set the bandwidth of each filter using the arrows at the bottom of the column (note the three sizes for coarse or fine adjustments) or you can edit the filter width graphically by using your mouse and grabbing the handles next to the filter number.
- **XO ver Type:** Sets the type of filter you will use for each of the crossover filters in the selected output. Use the arrows below the column to choose the type -- your first step first before any other editing of the crossover.
- **XO ver Freq.:** Set the frequency at which the filter roll-off begins using the arrows at the bottom of the column or you can edit the filter frequency graphically by using your mouse and grabbing the low or high filter icons that will appear at the bottom of the plot.
- **XO ver Slope:** Set the slope of the filter by using the arrows at the bottom of the column or you can edit the slope graphically by using your mouse and grabbing the handle that appears next to the filter icons at the bottom of the plot.

6.6 CREATING A NAVIGATOR NETWORK

Ethernet connection instructions for -EN version Navigators

Your -EN version Navigator can be controlled through a standard Ethernet connection. This option allows for control of up to 16 Navigators in one session of Navigator Remote Software.

There are three main procedures for creating your Navigator network. The first is patching your hardware, the second is assigning IP addresses to the Navigators, and the third is connecting your network using the Navigator software. You only have to do this once. From then on you will simply choose Connect and you will be controlling your network.

Hardware and Connections

1. Network Switch: In order to create your Navigator network you will need a network switch. This device comes in a variety of configurations. Choose one that has enough ports to accommodate all your Navigators plus the computer you will use for control. The maximum number of ports you will need is 17. Many companies offer switches, including NetGear, D-Link, 3Comm, Belkin, and Cisco.

2. Navigators: Press the System key on the front panel and scroll through the menus to the General Menu. Choose the Port parameter and change it to CAT-5.

SYSTEM-SETUP	MENU: General
FREQ MODE : 36	Steps/Oct
DELAY UNIT : ms	
DEVICE# : 1	PORT:CAT-5

Front panel LCD showing correct port setting

3. Ethernet cables: Connect your computer's network card to a port on the switch with a standard Ethernet cable (RJ45 connectors). Connect each Navigator's network connection to a port on the switch using standard Ethernet cables.

Assign Navigator IP addresses using DeviceInstaller

1. Install the Lantronix DeviceInstaller software. This software requires that your computer has .NET Framework 1.1 or higher. The DeviceInstaller utility comes on your Navigator CD Rom, or you can download it from Sabine.com. It does not make an icon on your desktop, so you must run it from Start - Programs.

2. Make sure your connections are made as described in the Hardware & Connections section above.

3. Run DeviceInstaller.

4. Click on the 'Search' button in DeviceInstaller. The connected Navigator(s) will be listed in the window. The Hardware Address shown is also displayed on the back panel of the Navigator.



DeviceInstaller main screen showing 9 Navigators with IP addresses successfully assigned

5. Select the first Navigator and click the 'Assign IP' button.

6. Select 'Assign a Specific IP address' in the dialog and click 'Next'

7. Enter the desired IP address, subnet mask (255.255.255.0 in all cases), and default gateway (0.0.0.0 in all cases) and click 'Next.'

- We recommend you follow this format for your IP addresses: **198.168.2.xxx**

- Choose any set of numbers in place of xxx. The network order of your Navigators depends on the sequence of these numbers, so plan accordingly. Device 1 in your Navigator network will be the lowest numbered IP address. Make a note of the complete address of each device - you will need this later.

- If you are incorporating this Navigator network into an existing network, please consult your system administrator before assigning IP addresses. Assigning an already existing address can cause your network to crash!

8. Click the 'Assign' button
9. Select the same Navigator in the main window again and click the 'Configure' menu button
10. Select the 'Ports' tab and click 'Edit Settings'
11. Change the Baud Rate to 115200, Data bits to 8, Parity to None, Stop bits to 1, and Flow Control to None. Click 'OK'
12. Repeat both procedures for all connected Navigators, making sure that each has a unique IP address.
13. Close DeviceInstaller. The Navigator(s) should now be ready for Ethernet connection.



Configuration screen in DeviceInstaller

Run Navigator Software and Connect to your Network

1. Run the Navigator software and choose 'Connection.'
2. Select 'Live Mode,' then select 'Network.'
3. Enter the IP addresses for all your Navigators. Make sure you use the same ones you assigned in the previous section. The order of your Navigators follows the numerical order of the IP addresses, so you can set the order in which you would like them to appear at this point. Choose 'OK.'
4. Navigators in your network will begin to connect, indicated by the bright green window in each device in the main screen. Choose the device you wish to control, and you are ready to go.
5. Save your setup! Choose 'Save Setup' and create a file. This will save all those IP addresses. You can load this file on another computer if you need to control the same Navigator network.
6. While in network mode the Link function is enabled. You can link all the main functions across devices and channels.



Main screen in Navigator Software, showing Connection window with IP addresses assigned and 10 devices present. Device 1 is not connected.

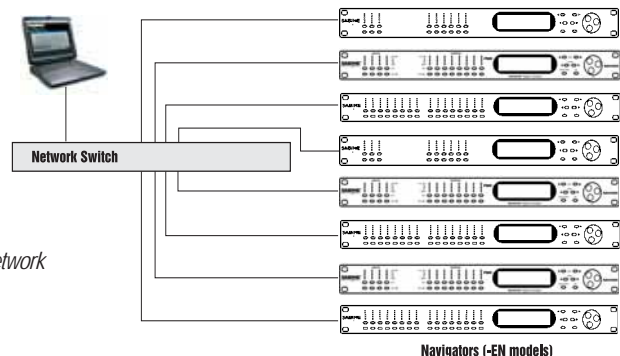

Hardware connections for a Navigator Network

Section Seven: Navigator Engineering Specifications

Inputs and Outputs

Input Impedance:>10k Ohms
 Output Impedance:50 Ohms
 Maximum Level:+20dBu
 Type: Electronically balanced

Audio Performance

Freq Response:±0.1dB (20 to 20kHz)
 Dynamic Range:115dB typ (unweighted)
 CMMR:>60dB (50 to 10kHz)
 Crosstalk:<-100dB
 Distortion:0.002%(1kHz @+4dBu)

Digital Audio Performance

Processor:32-bit (40-bit extended)
 Sampling Rate: 48kHz
 Analog Converters: High Performance 24-bit
 Propagation Delay: 1.47ms

Front Panel Controls

Display:4 x 26 Character Backlit LCD
 Level Meters:5 Segment LED
 Buttons: 12 Mute Controls
 12 Gain/Menu Controls
 6 Menu Controls
 Dial Encoder: Embedded Thumb Wheel

Connectors

Audio:3-pin XLR. Multi-pin Phoenix (NAV8800)
 RS-232:Female DB-9
 Power: Standard IEC Socket

General

Power:115 /230 VAC (50 /60Hz)
 Dimensions:19 "x1.75 "x 8 " (483 x 44 x 203mm)
 Weight:10 lbs /4.6 kg

Audio Control Parameters

Gain:-40 to +15dB in 0.25dB steps
 Polarity:+/-
 Delay: Up to 450ms per I/O
 Equalizers (6 per I/O)
 Type: Parametric, Hi-shelf, Lo-shelf
 FBX Feedback Exterminator®: 8 filters per input channel
 Crossover Filters (2 Filters per Output)
 Filter Types: Butterworth, Bessel, Linkwitz Riley
 Slopes: 6 to 48dB/oct

FBX/Parametric Filters

8 independent digital FBX filters per input channel,
 controlled automatically from 20 Hz to 20 KHz
 6 independent parametric/High Shelf/Lw Shelf filters per
 each input/output channel;
 Filter depth: user-controllable in 1 dB steps from +15 dB to -
 84 dB (parametric mode), 3 dB steps from 0 dB to -84 dB
 (FBX mode), maximum depth adjustable from -4 to -84 dB
 Filter width: user-controllable from 1.00 to .01 octave
 Resolution: 1 Hz from 20 Hz to 20 KHz in FBX and
 parametric mode
 Time required to find and eliminate feedback: typically 0.3
 seconds @ 1 KHz

Compressor/Limiter

Threshold: +20 dBu to -20 dBu
 Ratio: 1:1 through infinity
 Knee: soft/hard 4
 Attack:0.3 to 100ms
 Release:2 to 32X the attack time

System Parameters

Number of Programs:30
 Preset Configurations: Generic, 2, 3, 4-Way, plus other
 variations
 Front Panel & Software Security Locks: Any individual
 menu, password protected

Upgrades

Operating system firmware stored in Flash RAM. All
 future upgrades for firmware and software downloadable
 from Sabine website using Upgrade Wizard.

Notes:

-Below approximately 200 Hz the feedback filters become
 slightly wider to increase the feedback and rumble
 capture speed at these low frequencies.

-Tests performed using an Audio Precision System One
 model 322 or equal.

(SPECIFICATIONS SUBJECT TO CHANGE WITHOUT NOTICE)

One-year limited warranty
 Patented

Section Eight: Cautions & Warranty

Warning! This equipment must be earthed.

Caution! Risk of electric shock. Do not open.

Caution! Shock hazard. Do not remove covers. No user serviceable parts inside. Refer servicing to qualified service personnel.

Warning! To reduce the risk of fire or electric shock, do not expose this product to rain or moisture.

Attention! Cet appareil doit être relié à la terre.

Attention! Risque de choc électrique; ne pas ouvrir.

Attention! Risque de choc; ne pas ôter les capots. Aucune pièce accessible à l'intérieur. S'adresser à un technicien qualifié.

Attention! Pour réduire le risque d'incendie ou de choc électrique, ne pas laisser l'appareil sous la pluie ou à l'humidité.

Achtung! Dieses Gerät muss schutzgeerdet sein.

Achtung! Gefahr eines elektrischen Stromschlags. Gehäuse nicht öffnen.

Achtung! Gefahr eines elektrischen Stromschlags. Gehäuse nicht öffnen. Keine von Benutzer zu bedienenden Teile im Geräteinneren.

Überlassen Sie das Gerät zu Servicezwecken nur geschultem Fachpersonal.

Um Brandgefahr oder das Risiko eines elektrischen Schlags auszuschließen, das Gerät vor Nässe und Feuchtigkeit schützen.

Advertencia! Este equipo debe estar conectado a tierra.

Precaución! Riesgo de descarga eléctrica. No abrir.

Precaución! Riesgo de descarga eléctrica. No desmontar las tapas. Piezas interiores no reparables por el usuario. Reparable sólo por personal cualificado.

Advertencia! Para reducir el riesgo de incendio o de descarga eléctrica no exponga este producto a la lluvia o humedad.

FCC Statement:

This device complies with Part 15 of the FCC Rules. Operation is subject to the following conditions: (1) This device may not cause harmful interference; and (2) This device must accept any interference received, including interference that may cause undesired operation. *Warning:* Changes or modifications to this unit not expressly approved by the party responsible for compliance could void the user's authority to operate the equipment.

NOTE: This equipment has been tested and found to comply with the limits for a Class B digital device, pursuant to Part 15 of the FCC Rules. These limits are designed to provide reasonable protection against harmful interference in a residential installation. This equipment generates, uses, and can radiate radio frequency energy and, if not installed and used in accordance with the instructions, may cause harmful interference to radio communications. However, there is no guarantee that interference will not occur in a particular installation. If this equipment does cause harmful interference to radio or television reception, which can be determined by turning the equipment off and on, the user is encouraged to try to correct the interference by one or more of the following measures:

- Reorient or relocate the receiving antenna.
- Increase the separation between the equipment and receiver.
- Connect the equipment into an outlet on a circuit different from that to which the receiver is connected.
- Consult the dealer or an experienced radio TV technician for help.

Canadian Compliance Statement

This digital apparatus does not exceed the Class B limits for radio noise emissions from digital apparatus set out in the Radio Interference Regulations of the Canadian Department of Communications.

Le présent appareil numérique n'émet pas de bruits radioélectriques dépassant les limites applicables aux appareils numériques de la class B prescrites dans le Règlement sur le brouillage radioélectrique édicté par le ministère des Communications du Canada.

Japanese EMI Compliance Statement

この装置は、第二種情報装置

(住宅地域又はその隣接した地域において使用されるべき情報装置)で住宅地域での電波障害防止を目的とした情報処理装置等電波障害自主規制協議会 (VCCI) 基準に適合しております。

しかし、本装置をラジオ、テレビジョン受信機に近接してご使用になると、受信障害の原因となることがあります。

取扱説明書に従って正しい取り扱いをして下さい。



Warning!



The Navigator is designed to operate from standard AC power. Please be sure the power in your area is compatible with the power requirements marked on the rear of the unit. Using the wrong input voltage may cause permanent damage to the unit and will void the warranty.

The Navigator is supplied with one of the following AC power cords:

Japan	100 VAC
U.S./North America	120 VAC
Continental Europe	230 VAC
United Kingdom	240 VAC
Australia	240 VAC



Caution!



Replace the fuse with a fuse of exactly the same rating specified on the rear of the product.

1. Read all safety and operating instructions before using this product.
2. All safety and operating instructions should be retained for future reference.
3. Obey all cautions in the operating instructions and on the unit.
4. All operating instructions should be followed.
5. Use only shielded audio and data cables.
6. This product should not be used in the presence of moisture or rain, or near any water, i.e., a bathtub, sink, swimming pool, wet basement, etc.
7. This product should be located so that its position does not interfere with proper ventilation. Do not use in direct sunlight. Do not place flat against a wall or in a built-in enclosure that will impede the flow of cooling air.
8. This product should not be placed near a source of heat such as a stove or radiator.
9. Connect only to a power supply of the type marked on the unit adjacent to the power entry module.
10. Never break off the ground pin on the power supply cord.
11. Power supply cords should always be handled carefully. Never walk or place equipment on power supply cords. Periodically check cords for cuts or signs of stress, especially at the plug and the point where the cord exits the unit.
12. The power supply cord should be unplugged when the unit is to be unused for long periods of time.
13. Care should be taken so that objects do not fall and liquids are not spilled into the unit through the ventilation holes or any other openings.
14. This unit should be checked by a qualified service technician if:
 - A. The power supply cord or plug has been damaged.
 - B. Anything has fallen or been spilled into the unit.
 - C. The unit does not operate correctly.
 - D. The unit has been dropped or the enclosure damaged.
15. The user should not attempt to service this equipment. All service work should be done by a qualified service technician.

OSHA 2201; 1995 revised.

CAUTION 

EXPOSURE TO EXTREMELY HIGH NOISE LEVELS MAY CAUSE A PERMANENT HEARING LOSS. INDIVIDUALS VARY CONSIDERABLY IN SUSCEPTIBILITY TO NOISE INDUCED HEARING LOSS, BUT NEARLY EVERYONE WILL LOSE SOME HEARING IF EXPOSED TO SUFFICIENTLY INTENSE NOISE FOR A SUFFICIENT TIME. THE U.S. GOVERNMENT'S OCCUPATIONAL SAFETY AND HEALTH ADMINISTRATION (OSHA) HAS SPECIFIED THE FOLLOWING PERMISSIBLE NOISE LEVEL EXPOSURES:

DURATION/DAY IN HOURS	SOUND LEVEL IN dBA, SLOW RESPONSE
8	90
6	92
4	95
3	97
2	100
1-1/2	102
1	105
1/2	110
1/4 or less	115

ACCORDING TO OSHA, ANY EXPOSURE IN EXCESS OF THE ABOVE PERMISSIBLE LIMITS COULD RESULT IN HEARING LOSS. EAR PLUGS OR PROTECTORS IN THE EAR CANALS OR OVER THE EARS MUST BE WORN WHEN OPERATING THIS DEVICE IN ORDER TO PREVENT A PERMANENT HEARING LOSS, IF EXPOSURE IS IN EXCESS OF THE LIMITS AS SET FORTH ABOVE. TO ENSURE AGAINST POTENTIALLY DANGEROUS EXPOSURE TO HIGH SOUND PRESSURE LEVELS, IT IS RECOMMENDED THAT ALL PERSONS EXPOSED TO EQUIPMENT CAPABLE OF PRODUCING HIGH SOUND PRESSURE LEVELS SUCH AS THIS DEVICE BE PROTECTED BY HEARING PROTECTORS WHILE THIS UNIT IS IN OPERATION.

CAUTION 

This apparatus contains a lithium battery. Replacement shall be made by qualified service personnel only.
Call Sabine at (386) 418-2000 or consult an authorized Sabine agent.

FBX and FBX Feedback Exterminator are registered trademarks of Sabine, Inc., and are the brand names of its line of automatic feedback controllers. Covered by U.S. Patent No. 5,245,665, Australian Patent No. 653,736, Canadian Patent No. 2,066,624-2, German Patent No. 69118486.0, and U.K. Patent No. 0486679. Other patents pending.

Navigator, Graphi-Q, POWER-Q, REAL-Q, and REAL-Q2 are trademarks of Sabine, Inc.
Copyright 2005. All rights reserved.

Limited Warranty

THIS LIMITED WARRANTY VALID ONLY WHEN PURCHASED AND REGISTERED IN THE UNITED STATES OR CANADA. ALL EXPORTED PRODUCTS ARE SUBJECT TO WARRANTY AND SERVICES TO BE SPECIFIED AND PROVIDED BY THE AUTHORIZED DISTRIBUTOR FOR EACH COUNTRY.

Ces clauses de garantie ne sont valables qu'aux Etats-Unis et au Canada. Dans tous les autres pays, les clauses de garantie et de maintenance sont fixées par le distributeur national et assurées par lui selon la législation en vigueur.

Diese Garantie ist nur in den USA und Kanada gültig. Alle Export-Produkte sind der Garantie und dem Service des Importeurs des jeweiligen Landes unterworfen.

Esta garantía es válida solamente cuando el producto es comprado en E.U. continentales o en Canada. Todos los productos que sean comprados en el extranjero, están sujetos a las garantías y servicio que cada distribuidor autorizado determine y otorgue en los diferentes países.

ONE-YEAR LIMITED WARRANTY/REMEDY

SABINE, INC. ("SABINE") warrants this product to be free from defects in material and workmanship for a period of one (1) year from date of purchase PROVIDED, however, that this limited warranty is extended only to the original retail purchaser and is subject to the conditions, exclusions and limitations hereinafter set forth:

CONDITIONS, EXCLUSIONS AND LIMITATIONS OF LIMITED WARRANTIES

These limited warranties shall be void and of no effect if:

- The first purchase of the product is for the purpose of resale; or
- The original retail purchase is not made from an AUTHORIZED SABINE DEALER; or
- The product has been damaged by accident or unreasonable use, neglect, improper service or maintenance, or other causes not arising out of defects in material or workmanship; or
- The serial number affixed to the product is altered, defaced or removed; or
- The power supply grounding pin is removed or otherwise defeated. In the event of a defect in material and/or workmanship covered by this limited warranty, Sabine will repair the defect in material or workmanship or replace the product, at Sabine's option; and provided, however, that, in any case, all costs of shipping, if necessary, are paid by you, the purchaser.

THE WARRANTY REGISTRATION CARD SHOULD BE ACCURATELY COMPLETED, MAILED TO AND RECEIVED BY SABINE WITHIN FOURTEEN (14) DAYS FROM THE DATE OF YOUR PURCHASE.

In order to obtain service under these warranties, you must:

- Bring the defective item to any Authorized SABINE DEALER and present therewith the ORIGINAL PROOF OF PURCHASE supplied to you by the AUTHORIZED SABINE DEALER in connection with your purchase from him of this product. If the DEALER is unable to provide the necessary warranty service, you will be directed to the nearest other SABINE AUTHORIZED DEALER which can provide such service.

OR

- Ship the defective item, prepaid, to:

SABINE, INC.
13301 HIGHWAY 441
ALACHUA, FL 32615-8544

including therewith a complete, detailed description of the problem, together with a legible copy of the original PROOF OF PURCHASE and a complete return address. Upon Sabine's receipt of these items:

If the defect is remedial under the limited warranties and the other terms and conditions expressed have been complied with, Sabine will provide the necessary warranty service to repair or replace the product and will return it, FREIGHT COLLECT, to you, the purchaser.

Sabine's liability to the purchaser for damages from any cause whatsoever and regardless of the form of action, including negligence, is limited to the actual damages up to the greater of \$500.00 or an amount equal to the purchase price of the product that caused the damage or that is the subject of or is directly related to the cause of action. Such purchase price will be that in effect for the specific product when the cause of action arose. This limitation of liability will not apply to claims for personal injury or damage to real property or tangible personal property allegedly caused by Sabine's

negligence. Sabine does not assume liability for personal injury or property damage arising out of or caused by a non-Sabine alteration or attachment, nor does Sabine assume any responsibility for damage to interconnected non-Sabine equipment that may result from the normal functioning and maintenance of the Sabine equipment.

UNDER NO CIRCUMSTANCES WILL SABINE BE LIABLE FOR ANY LOST PROFITS, LOST SAVINGS, ANY INCIDENTAL DAMAGES OR ANY CONSEQUENTIAL DAMAGES ARISING OUT OF THE USE OR INABILITY TO USE THE PRODUCT, EVEN IF SABINE HAS BEEN ADVISED OF THE POSSIBILITY OF SUCH DAMAGES.

THESE LIMITED WARRANTIES ARE IN LIEU OF ANY AND ALL WARRANTIES, EXPRESS OR IMPLIED, INCLUDING BUT NOT LIMITED TO, THE IMPLIED WARRANTIES OF MERCHANTABILITY AND FITNESS FOR A PARTICULAR USE; PROVIDED, HOWEVER, THAT IF THE OTHER TERMS AND CONDITIONS NECESSARY TO THE EXISTENCE OF THE EXPRESS LIMITED WARRANTIES, AS HEREIN ABOVE STATED, HAVE BEEN COMPLIED WITH, IMPLIED WARRANTIES ARE NOT DISCLAIMED DURING THE APPLICABLE ONE-YEAR PERIOD FROM DATE OF PURCHASE OF THIS PRODUCT.

SOME STATES DO NOT ALLOW LIMITATION ON HOW LONG AN IMPLIED WARRANTY LASTS, OR THE EXCLUSION OR LIMITATION OF INCIDENTAL OR CONSEQUENTIAL DAMAGES, SO THE ABOVE LIMITATIONS OR EXCLUSIONS MAY NOT APPLY TO YOU. THESE LIMITED WARRANTIES GIVE YOU SPECIFIC LEGAL RIGHTS, AND YOU MAY ALSO HAVE OTHER RIGHTS WHICH MAY VARY FROM STATE TO STATE.

THESE LIMITED WARRANTIES ARE THE ONLY EXPRESS WARRANTIES ON THIS PRODUCT, AND NO OTHER STATEMENT, REPRESENTATION, WARRANTY OR AGREEMENT BY ANY PERSON SHALL BE VALID OR BINDING UPON SABINE.

In the event of any modification or disclaimer of express or implied warranties, or any limitation of remedies, contained herein conflicts with applicable law, then such modification, disclaimer or limitation, as the case may be, shall be deemed to be modified to the extent necessary to comply with such law.

Your remedies for breach of these warranties are limited to those remedies provided herein, and Sabine gives this limited warranty only with respect to equipment purchased in the United States of America.

INSTRUCTIONS-WARRANTY REGISTRATION CARD

1. Mail the completed WARRANTY REGISTRATION CARD to:

SABINE, INC.
13301 HIGHWAY 441
ALACHUA, FL 32615-8544

- a. Keep the PROOF OF PURCHASE. In the event warranty service is required during the warranty period, you will need this document. There will be no identification card issued by Sabine, Inc.

2. IMPORTANCE OF WARRANTY REGISTRATION CARDS AND NOTIFICATION OF CHANGES OF ADDRESS:

- a. Completion and mailing of WARRANTY REGISTRATION CARDS - Should notification become necessary for any condition that may require correction, the REGISTRATION CARD will help ensure that you are contacted and properly notified.

- b. Notice of address changes - If you move from the address shown on the WARRANTY REGISTRATION CARD, you should notify Sabine of the change of address so as to facilitate your receipt of any bulletins or other forms of notification which may become necessary in connection with any condition that may require dissemination of information or correction.

3. You may contact Sabine directly by telephoning (386) 418-2000.

4. Please have the Sabine product name and serial number available when communicating with Sabine Customer Service.

Sabine, Inc.
13301 NW US Highway 441
Alachua, Florida 32615-8544 USA
Phone: (386) 418-2000 • Fax: (386) 418-2001
www.Sabine.com • sabine@sabine.com

SABINE[®]
ADAPTIVE AUDIO