

TRUE MOBILITY™

WIRELESS SYSTEMS

2.4 GHz / 915 MHz Smart Spectrum® Extension Antenna Kit SWASS-EXT-3-M1 / SWASS-EXT-3-M9 Operating Guide

This guide is for use with

SWM7000-M1 Series models:

**SW71-R-M1
SW72-R-M1
SW72-NDR-M1
SWA6SS-M1**

SWM6000-M9 Series models:

**SW61-R-M9
SW62-R-M9
SW62-NDR-M9
SWA6SS-M9**

SWASS-EXT-3 benefits

- Wall mount or mic-stand mount
- 130 degree reception pattern
- Variable gain,
2.4GHz: 0 to 30 dB / 915 MHz: 0 to 24 dB
- Wood-tone finish
- Phantom-powered from either the receiver or the distribution amp; Power LED indicator

Included with the SWASS-EXT-3

- One pair of antennas, each with mic stand mounts attached
- Two European mic stand adaptor inserts
- Operating Guide

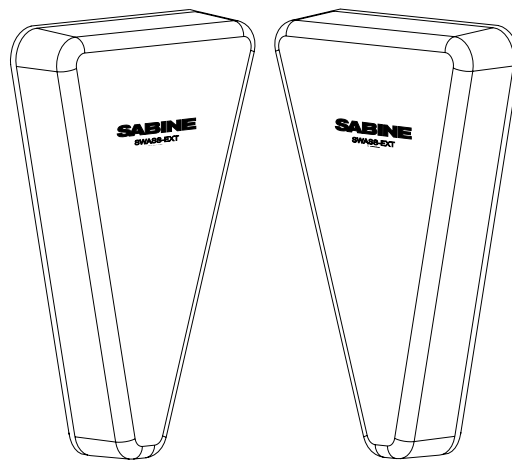

SABINE®
the sound of innovation

OVERVIEW

The SWASS-EXT-3-M1 Antenna Extension Kit is designed for use with Sabine SWM7000 2.4 GHz and the SWASS-EXT-3-M9 is for use with the SWM6000 915 MHz. wireless microphone receivers and antenna distribution amplifiers. Both of the SWASS-EXT-3 units allow for optimal placement of external antennas for maximum wireless performance. One SWASS-EXT-3 kit can accommodate up to 70 receiver channels. (See block diagram detail on page 10).

ANTENNA PLACEMENT

Extension antennas should be placed in an open area within visual range of the intended transmitter locations. Note that the range of a True Mobility transmitter is about 100 meters, but that structural objects can reduce that range.

CAUTIONS

- Since the installation of the antennas influences the operating efficiency of the receiver, the most important rule is to minimize the distance between receiving antenna and transmitter for better reception and performance. Make sure the antennas can “see” the transmitter.
- Keep the system away from electrical-noise sources (electric motors, refrigerators, arc welders, etc.). Place the SWM7000/SWM6000 receiver or SWA6SS Antenna Distribution Amplifier at least 1.5 meters above floor level. Keep all transmitters at least 3 meters away from a receiver antenna.

ANTENNA CABLING & CABLE LOSS

While an extension antenna affords the opportunity to increase the distance from transmitter to receiver, there is a loss of signal in the interconnecting cable that limits that distance. The maximum connection length is determined by the type of cable used, and the degree of signal attenuation acceptable.

Let’s presume that an acceptable degree of loss over the total cable run is 6 dB. Without external signal boosts, the different cables shown in the table would then allow maximum lengths ranging from less than 4 M (RG-58) to 24 M (RG8/U). Thus, for a passive extension antenna, your choices are to limit the cable run, or increase your budget and buy the more expensive, thicker cable.

Coaxial Cable Attenuation Table				10 Meter Attenuation (dB)				Maximum Practical Distance using SWASS-EXT set for +22 dB boost (meters)		Connector Type
Cable Type	Belden #	Insulation	Center Conductor	2.4 GHz	915 MHz	2.4 GHz	915 MHz			
RG58	9203	Polyethylene	#20 Stranded	-16.29	-6.5	14	35	TNC		
RG58/AU	9311	Foam Polyethylene	#20 Stranded	-11.10	-4.7	20	47	TNC		
RG212/U	9861	Polyethylene	#15.5 solid, silver plated	-6.11	-3.0	36	73	N		
RG8/U	9913	Semi-solid Polyethylene	#10 solid	-2.50	-1.3	88	170	N		
RG142	83242	Teflon	#18 solid, silver plated	-6.54	-4.0	34	55	TNC		

Fortunately, Sabine's SWASS-EXT-3 Active Extension Antenna offers a far better, more cost-effective solution, due to its built-in active 18 dB signal boost. In the case of low-cost RG-58 cable, adding an SWASS-EXT-3 to your setup increases the acceptable maximum cable run by more than 4 times, to 14 meters. With RG-8 cable, the maximum length is extended to 88 meters!

Power for the Extension Antenna is delivered from any Sabine SWM7000/SWM6000 series receiver or SWA6SS Antenna Distribution Amplifier.

An additional advantage of using Sabine's SWASS-EXT-3 Extension Antenna stems from its more focused, directional nature. Sabine receiver's coaxial dipole antennas (standard equipment that mount directly on the front or rear panels of the receiver or SWA6SS) are more omni directional in nature. In contrast, the Sabine's Extension Antenna is sensitive to RF reception in a 180-degree arc in front of its mounted position. It extends sensitivity to the front and off-axis side locations as it increases rear RF rejection.

The multiple functions (relocation of antenna, boost of signal, directional sensitivity) of Sabine's Extension Antenna mean there are many applications in which its addition to your system can greatly enhance performance. Here's a partial list of such applications:

- 1. Antenna repositioning.** Provides solutions when receiver placement options are limited or challenging. Sabine's Extension Antenna's multiple mounting options allow higher placement (wall mount or microphone stand mount).
- 2. Barriers interrupting transmission.** Any time a barrier interferes with transmission and reception, Sabine's SWASS-EXT-3 can be mounted on the transmitter side of the barrier with cable connections made on the receiver side. The most common situation of this nature would arise when receiver and transmitter are located in separate rooms.
- 3. Expanded or directional sensitivity required.** Sabine's Extension Antenna picks up in a 180-degree arc, focused towards the front. Reception in this arc is enhanced.
- 4. Rear RF rejection required.** Because Sabine's Extension Antenna is less sensitive to signals received from the rear, it can be positioned to reject any such directional RF interference.
- 5. Extended operational range.** Given a potential maximum cable length of almost 90 meters from Extension Antenna to receiver, Sabine's SWASS-EXT-3 allows more options for extending the distance between transmitter and receiver. Consider that RF signal strength through air is diminished by the square of the distance (twice as far away = $\frac{1}{4}$ the signal strength), while signal loss through cable is (roughly) inversely proportional (twice as far away = $\frac{1}{2}$ the signal). That means you can use an extension antenna to replace transmission-through-air with transmission-through-cable, to help minimize signal loss.
- 6. Variable Gain.** This model allows for continuously variable gain settings from 0 to +30 dB (2.4GHz) and 0 to +24 dB (915MHz). There should be a minimum of 12dB of cable loss before the antenna gain is set to the maximum gain setting of +44 dB. If maximum gain is set with less than 12dB of cable loss the receiver front end may get overloaded. Refer to the chart at left and use maximum gain only for extending the maximum practical distance of the cable you are using. See page 7 for instructions on setting the antenna gain.

SWASS-EXT-3 (2.4 GHz / 915 MHz) EXTERNAL ANTENNA

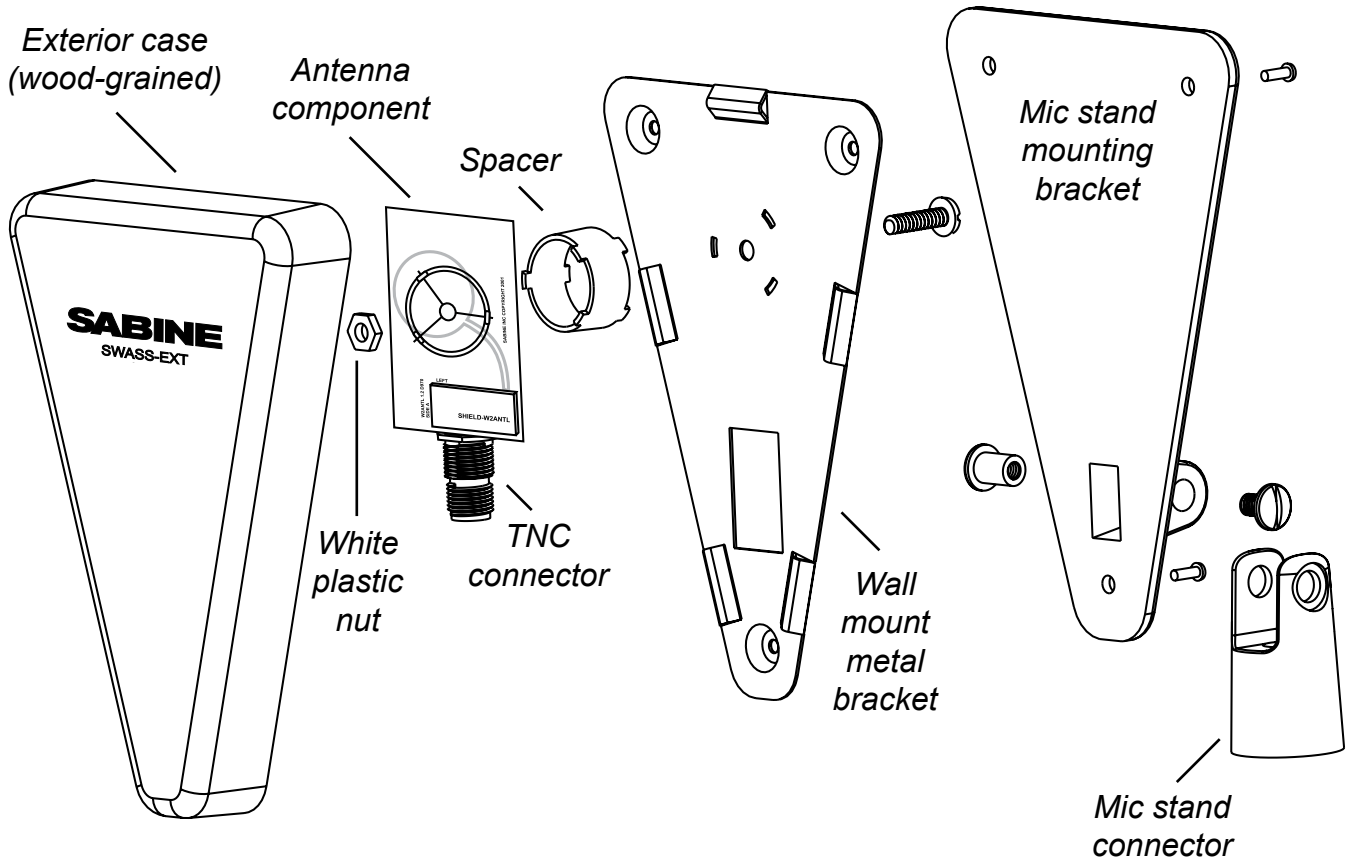

GENERAL INSTRUCTIONS

- 1 Locate and install the antennas so that they are within line-of-sight of intended wireless microphone locations.

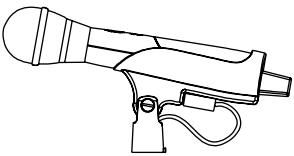

Line-of-sight path



- 2 Connect the SWASS-EXT-3 to either antenna input on your SWM7000 /SWM6000 receiver or SWA6SS Antenna Distribution Amplifier.

MOUNTING INSTRUCTIONS

SWASS-EXT-3 Antennas can be permanently mounted on wall surfaces, or affixed to the top of microphone stands for convenient re-positioning.

1 MICROPHONE STAND MOUNTING

Attach SWASS-EXT-3 Antenna Kits to microphone stands and position stands in desired locations.

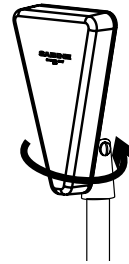

2 Gently pry the wood-grained exterior case from the rest of the antenna assembly.

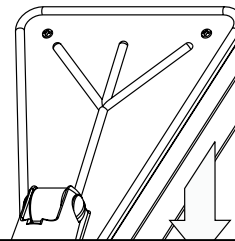

3 Attach antenna cable to TNC connector on the antenna assembly. Hand tighten only. Reattach the wood-grain exterior case



4 Placing Extension Antennas

Position antennas about 10-15 feet apart. When you mount the extension antennas on a stand or on a wall, make sure the wide side of the triangle is up, as shown above.

In order for the system to be effective, **both extension antennas should be in a good pickup position at all times** but separated by about ten or fifteen feet if the antennas are within 100 or so feet. Separate them about 20 to 25 feet in very large rooms or fields.

If you put the antennas too far apart, i.e., at opposite ends of the room, or in separate rooms, to improve coverage, diversity is defeated and you will get dropouts. In other words, diversity is more important than coverage. If you mount the **extension antennas in the ceiling**, the antennas metallic backplane must be orientated parallel to the floor and the antennas must not be blocked by pillars, lights or similar obstructions. Aim the hole in the plastic cover toward the podium.

Do not daisy-chain extension antennas together in series. Receivers and the antenna distribution amp are only designed to use one left and one right antenna.

Extension Antenna Cables: Use coax cable to connect the extension antennas to the receiver or to the ADA. See the chart on the previous page for cable specifications. Use the SWATNC-N step-down cable to connect thicker RG8 cables to the extension antenna.

The SWASS-EXT-3 extension antennas add between 0 and +30 dB (2.4 GHz), / 0 and +44 dB (915MHz) signal strength to overcome cable loss. See page 7 for instructions on setting the antenna gain. **Bad crimp connections are a common cause of dropouts.** Check them carefully!

WALL MOUNTING

CAUTION: Be careful not to scratch or damage the interior components of the SWASS-EXT-3 Antenna Kit. Interior components can be disassembled and reassembled using fingers. Do not use metal pliers, wrenches, screwdrivers or knives to unscrew or tighten interior antenna components to the metal antenna bracket frame.

- 1 Gently pry the wood-grained exterior case from the rest of the antenna assembly.

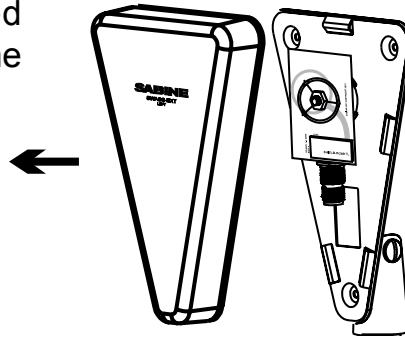

- 2 Unscrew the black microphone mount from the antenna assembly.

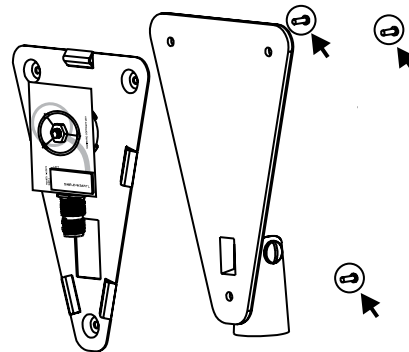

- 3 Using fingers only, unscrew the white plastic nut and remove the antenna component from the metal bracket.

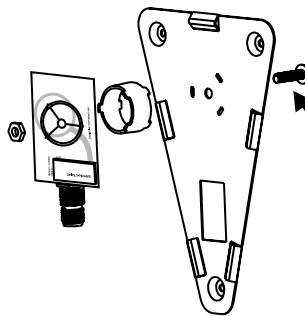

- 4 Attach a TNC elbow* to your antenna cable and thread the elbow through the rectangular metal cutaway in the wall-mount bracket. Screw the TNC elbow onto the separated antenna component so that the cable end will go through the cutaway. Tighten finger tight only.

*TNC elbow not included

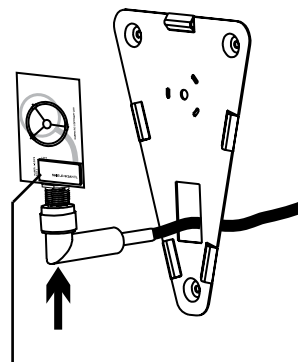

NOTE: Make sure the rectangular silver shield case (SHIELD-W2ANTL) will face away from the bracket when the component has been remounted.

5 Reconnect the antenna component to the metal bracket with the TNC elbow positioned through the cutaway. Tighten the white plastic nut finger tight only.

6 Mount the metal wall-mount bracket to the predetermined location on the wall.

7 Replace the wood-grain antenna exterior case.

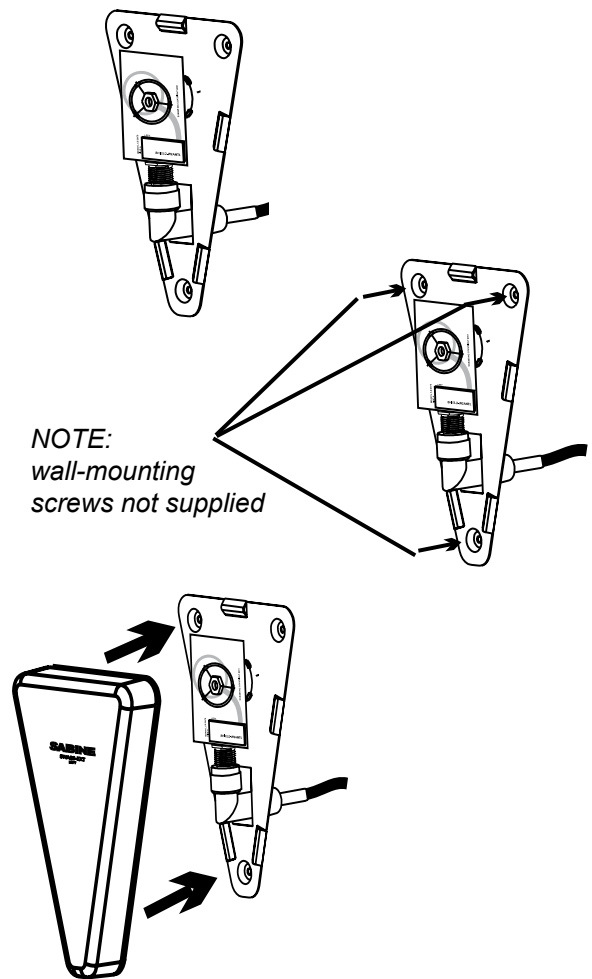

SETTING ANTENNA GAIN / POWER LED INDICATOR

Instructions for adjusting the gain on Sabine SWASS extension antennas.

Introduction

The Sabine SWASS extension antenna is an active antenna. This means it can amplify the RF signal it receives before transmitting it to the cable it is attached to. The reason it has this ability is to make up for the loss in the cable connecting it to the Antenna Distribution Amplifier (ADA) or SWM receiver. For example, RG8 cable has a loss at 2.4 GHz of approximately 7.4dB per 100 feet. Therefore, the correct gain for the SWASS would be 7.4dB for 100 feet of RG8. Although it might seem like a good idea to add even more gain in an attempt to extend the range of the transmitters, don't do it. It will cause signal clipping in the receiver which will lead to audible artifacts and reduced, not increased range. This document explains how to correctly set the gain pot on the SWASS for optimum range and system performance.

Setting the Gain

NOTE: You will need to have one of your receivers connected to a PC running the Sabine SWM remote software to perform this procedure. Once you have your antennas installed in their correct positions, follow the procedure below.

1. Turn on all of the transmitters that you will be using with your system. Make sure they are all on different channels. Leave one channel open in the middle of the channel line up for use in the calibration procedure that follows. For example, if you are using channels 1 – 20, skip channel 10. IE, no transmitter on channel 10.

2. Place the transmitters in the general area where they will be used, IE the stage.
3. Connect one of your receivers to the SWM remote software.
4. Click on the RF Scan button to open the RF scanner.
5. In the scan range boxes, enter the open channel in both the start and stop range. For example, if using channel 10 as shown in step 1 above, enter 10 in the “from” and “to” range boxes.
6. Click the start button to start scanning on channel 10.
7. Go to one of your extension antennas and turn the gain all the way down.
8. Go to the other antenna and turn the gain up until you start seeing a red or yellow bar on the RF chart on the channel you are scanning. Now slowly turn the gain down until it just goes away.
9. Go to the other antenna and repeat the same procedure, turning the gain down just until the red/yellow bar disappears.

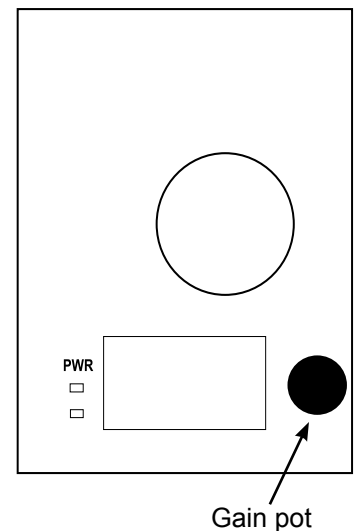

Your extension antennas are now correctly set.

note: The extension antenna wizard can also be used to set the gain. To launch it, click the “Extension antenna wizard” button on the RF scan dialog in the GUI and follow the instructions.

INSTALLATION CAUTIONS

Extension Antenna cables — For best results, use high quality coaxial cable with a 50 Ohm impedance. Specifications will vary by cable manufacturer. For best results, use cable with minimal attenuation. The longer your cable, the more you will reduce the 100-meter range between transmitter and receiver antenna. A well-placed pair of extension antennas will eliminate trouble spots and generally improve overall performance of the wireless.

COMMON SOURCES OF RF INTERFERENCE

The typical sources of interference for conventional wireless mics can be high-powered broadcasters such as radio stations and TV transmitters, or other short-range wireless devices, including multiple radio microphones operating at the same location (either by design, or by coincidence), that operate in proximate (or harmonically related) bands. Less commonly, interference may arise from spurious outputs emitted by electronic equipment (notably computers, printers, or similar devices with digital clocks), faulty electrical equipment, neon signs, dimmers and lighting controllers, and so forth.

Many UHF and VHF mics are especially vulnerable because they share the RF spectrum with the very high-powered transmitters for television. The coming conversion to digital and high-definition broadcast will increase the problems for UHF and VHF.

The 2.4 to 2.4835 GHz frequency band is not only well above the fundamental (nominal) transmission frequencies of such strong analog and digital broadcasts, but also high enough to escape interference problems occurring at the strong first harmonic of even the highest digital television broadcast. The band is approved worldwide for a variety of uses, including such diverse transmitters as baby monitors, garage door openers, wireless LANs, amateur satellite, cordless telephones, etc. Compared to RF broadcast sources like television and

radio stations, these low power devices produce very localized, short range interference; furthermore, many of the devices working in the 2.4 GHz range use spread spectrum transmission and reception. Both of these facts mean such uses of the RF spectrum are less likely to cause interference with, or suffer from interference from the use of, Sabine's systems.

Your first step in checking for interference should be utilizing the Scan function in the SWM7000 / SWM6000 Remote Control Software. RF scanning will reveal potential RF sources in your location and allow you to make an informed choice of channels to use. The scanner can scan for long periods of time and will give you a report of RF activity over time for each of the channels available on your Smart Spectrum system. See Section 13.4.2.5 RF Scan of the SWM7000 / SWM6000 Operating Guide for more details on RF scanning.

1. Microwave ovens

In the vast majority of situations, interference from microwave ovens will not affect performance of your SWM7000 / SWM6000 series microphone systems. Since barriers such as walls work to block interference, a microwave oven will likely present a problem only when located in fairly close proximity within the same room as the wireless receiver (or reception antenna). See caution below.

Commercial quality microwave ovens present a bigger potential problem. They sweep over a wider band of frequencies than the limited band affected by consumer units, and use two magnetron tubes which alternate to avoid inactivity during a power cycle. Fortunately, Sabine systems are only affected by such ovens in close proximity to receiver antennas. That protection, plus the availability of multiple RF channels to choose from, makes serious interference problems arising from microwave ovens avoidable and unlikely. See caution below.

2. Wireless Local Area Networks (WLANS)

These computer network devices allow computers to connect via wireless devices that act as both receivers and transmitters. These low-powered transceivers often have selectable channels and can utilize the entire 2.4 GHz band. In general, Sabine microphones should not be affected by these WLANS because their spread spectrum technology does not present a problem for the Sabine Smart Spectrum™ system. See caution below.

3. Cordless phones

These home telephones broadcast at very low power and should not present interference problems for your Sabine wireless. This is especially true if the telephone uses spread spectrum technology. See caution below.

4. Wireless Video Cameras

Certain wireless video cameras (X10, for example) use the 2.4 GHz band. These devices are also very low power and, in general, should not present a problem when using the SWM7000 / SWM6000 system. See Section 5 Receiver Operation for methods of optimizing clear reception and minimizing interference. See caution below.

Antenna Placement Caution

As a general precaution, keep 2.4 GHz cordless telephones, microwave ovens, WLAN antennas and 2.4 GHz wireless video camera transmitters twice the distance from your Sabine wireless microphone system antennas as that of your Sabine 2.4 GHz transmitters.

SWASS-EXT Block Diagram

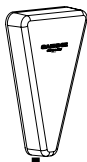

SWASS-EXT-3 External Antenna

SWASS-EXT-3 External Antenna

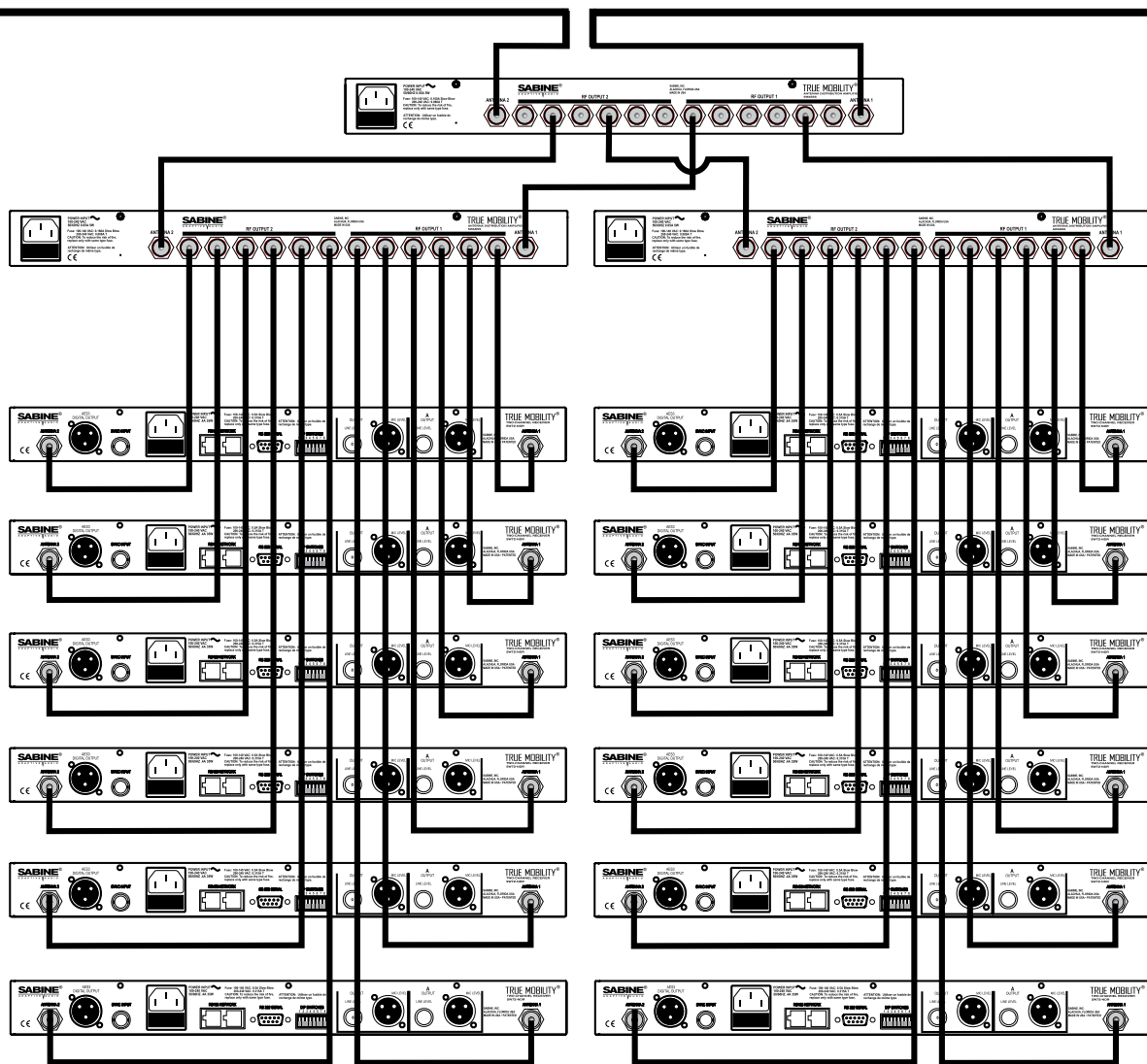
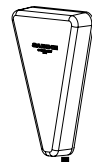

NOTE: When using multiple Antenna Distribution Amps, make sure and connect the extension antennas to the first distribution amp, and distribute the signal to the rest of the distribution amps. These other amps should then be connected to the receivers, as shown in the diagram above.

⚠ IMPORTANT ⚠

Active Electronics Antenna

Sabine wireless receivers provide antennas with active electronics. The inputs to the receiver & antenna distributor amplifier have phantom power available for this purpose.

DO NOT SHORT TO GROUND

WARRANTY

FBX and FBX Feedback Exterminator® are registered trademarks of Sabine, Inc., and are the brand names of its line of automatic feedback controllers. Covered by U.S. Patent No. 5,245,665, Australian Patent No. 653,736, Canadian Patent No. 2,066,624-2, German Patent No. 69118486.0, and U.K. Patent No. 0486679. Other patents pending. True Mobility® is a trademark of Sabine, Inc. Copyright 2004 Sabine, Inc. All rights reserved.

THIS LIMITED WARRANTY VALID ONLY WHEN PURCHASED AND REGISTERED IN THE UNITED STATES OR CANADA. ALL EXPORTED PRODUCTS ARE SUBJECT TO WARRANTY AND SERVICES TO BE SPECIFIED AND PROVIDED BY THE AUTHORIZED DISTRIBUTOR FOR EACH COUNTRY.

Ces clauses de garantie ne sont valables qu'aux Etats-Unis et au Canada. Dans tous les autres pays, les clauses de garantie et de maintenance sont fixées par le distributeur national et assurées par lui selon la législation en vigueur.

Diese Garantie ist nur in den USA and Kanada gültig. Alle Export-Produkte sind der Garantie und dem Service des Importeurs des jeweiligen Landes unterworfen.

Esta garantía es válida solamente cuando el producto es comprado en E.U. continentales o en Canada. Todos los productos que sean comprados en el extranjero, están sujetos a las garantías y servicio que cada distribuidor autorizado determine y otorgue en los diferentes países.

ONE-YEAR LIMITED WARRANTY/REMEDY

SABINE, INC. ("SABINE") warrants this product to be free from defects in material and workmanship for a period of one (1) year from date of purchase PROVIDED, however, that this limited warranty is extended only to the original retail purchaser and is subject to the conditions, exclusions and limitations hereinafter set forth:

CONDITIONS, EXCLUSIONS & LIMITATIONS OF LIMITED WARRANTIES

These limited warranties shall be void and of no effect if:

- a. The first purchase of the product is for the purpose of resale; or
- b. The original retail purchase is not made from an AUTHORIZED SABINE DEALER; or
- c. The product has been damaged by accident or unreasonable use, neglect, improper service or maintenance, or other causes not arising out of defects in material or workmanship; or
- d. The serial number affixed to the product is altered, defaced or removed; or
- e. The power supply grounding pin is removed or otherwise defeated. In the event of a defect in material and/or workmanship covered by this limited warranty, Sabine will repair the defect in material or workmanship or replace the product, at Sabine's option; and provided, however, that, in any case, all costs of shipping, if necessary, are paid by you, the purchaser.

THE WARRANTY IS NOT VALID UNLESS REGISTERED ONLINE (www.sabine.com) AND RECEIVED BY SABINE WITHIN FOURTEEN (14) DAYS FROM THE DATE OF YOUR PURCHASE.

In order to obtain service under these warranties, you must:

- a. Bring the defective item to any Authorized SABINE DEALER and present therewith the ORIGINAL PROOF OF PURCHASE supplied to you by the AUTHORIZED SABINE DEALER in connection with your purchase from him of this product. If the DEALER is unable to provide the necessary warranty service, you will be directed to the nearest other SABINE AUTHORIZED DEALER which can provide such service. OR:
- b. Ship the defective item, prepaid, to:
SABINE, INC.
13301 NW US HIGHWAY 441
ALACHUA, FL 32615-8544

Include therewith a complete, detailed description of the problem, together with a legible copy of the original PROOF OF PURCHASE and a complete return address. Upon Sabine's receipt of these items:

If the defect is remedial under the limited warranties and the other terms and conditions expressed have been complied with, Sabine will provide the necessary warranty service to repair or replace the product and will return it, FREIGHT COLLECT, to you, the purchaser.

Sabine's liability to the purchaser for damages from any cause whatsoever

and regardless of the form of action, including negligence, is limited to the actual damages up to the greater of \$500.00 or an amount equal to the purchase price of the product that caused the damage or that is the subject of or is directly related to the cause of action. Such purchase price will be that in effect for the specific product when the cause of action arose. This limitation of liability will not apply to claims for personal injury or damage to real property or tangible personal property allegedly caused by Sabine's negligence. Sabine does not assume liability for personal injury or property damage arising out of or caused by a non-Sabine alteration or attachment, nor does Sabine assume any responsibility for damage to interconnected non-Sabine equipment that may result from the normal functioning and maintenance of the Sabine equipment.

UNDER NO CIRCUMSTANCES WILL SABINE BE LIABLE FOR ANY LOST PROFITS, LOST SAVINGS, ANY INCIDENTAL DAMAGES OR ANY CONSEQUENTIAL DAMAGES ARISING OUT OF THE USE OR INABILITY TO USE THE PRODUCT, EVEN IF SABINE HAS BEEN ADVISED OF THE POSSIBILITY OF SUCH DAMAGES.

THESE LIMITED WARRANTIES ARE IN LIEU OF ANY AND ALL WARRANTIES, EXPRESS OR IMPLIED, INCLUDING BUT NOT LIMITED TO, THE IMPLIED WARRANTIES OF MERCHANTABILITY AND FITNESS FOR A PARTICULAR USE; PROVIDED, HOWEVER, THAT IF THE OTHER TERMS AND CONDITIONS NECESSARY TO THE EXISTENCE OF THE EXPRESS LIMITED WARRANTIES, AS HEREINABOVE STATED, HAVE BEEN COMPLIED WITH, IMPLIED WARRANTIES ARE NOT DISCLAIMED DURING THE APPLICABLE ONE-YEAR PERIOD FROM DATE OF PURCHASE OF THIS PRODUCT.

SOME STATES DO NOT ALLOW LIMITATION ON HOW LONG AN IMPLIED WARRANTY LASTS, OR THE EXCLUSION OR LIMITATION OF INCIDENTAL OR CONSEQUENTIAL DAMAGES, SO THE ABOVE LIMITATIONS OR EXCLUSIONS MAY NOT APPLY TO YOU. THESE LIMITED WARRANTIES GIVE YOU SPECIFIC LEGAL RIGHTS, AND YOU MAY ALSO HAVE OTHER RIGHTS WHICH MAY VARY FROM STATE TO STATE.

THESE LIMITED WARRANTIES ARE THE ONLY EXPRESS WARRANTIES ON THIS PRODUCT, AND NO OTHER STATEMENT, REPRESENTATION, WARRANTY OR AGREEMENT BY ANY PERSON SHALL BE VALID OR BINDING UPON SABINE.

In the event of any modification or disclaimer of express or implied warranties, or any limitation of remedies, contained herein conflicts with applicable law, then such modification, disclaimer or limitation, as the case may be, shall be deemed to be modified to the extent necessary to comply with such law.

Your remedies for breach of these warranties are limited to those remedies provided herein, and Sabine gives this limited warranty only with respect to equipment purchased in the United States of America.

INSTRUCTIONS for WARRANTY REGISTRATION

1. Register online at www.Sabine.com

- a. Keep the PROOF OF PURCHASE. In the event warranty service is required during the warranty period, you will need this document. There will be no identification card issued by Sabine, Inc.

IMPORTANCE OF WARRANTY REGISTRATION & NOTIFICATION OF CHANGES OF ADDRESS:

- a. Completion of Warranty Registration Card — Should notification become necessary for any condition that may require correction, the online registration will help ensure that you are contacted and properly notified.
- b. Notice of email address changes - If you change email address shown on the Warranty Registration Card, you should notify Sabine of the change so as to facilitate your receipt of any bulletins or other forms of notification which may become necessary in connection with any condition that may require dissemination of information or correction.
3. You may contact Sabine directly by telephoning (386) 418-2000.
4. Please have the Sabine product name and serial number available when communicating with Sabine Customer Service.

SABINE, INC.
13301 NW US HIGHWAY 441
ALACHUA, FLORIDA 32615-8544 USA
Phone: +USA (386) 418-2000
Fax: +USA (386) 418-2001



IMPORTANT



Active Electronics Antenna

Sabine wireless receivers provide antennas with active electronics. The inputs to the receiver & antenna distributor amplifier have phantom power available for this purpose.

DO NOT SHORT TO GROUND

SABINE
the sound of innovation

13301 NW US Highway 441 • Alachua, Florida 32615 - 8544 USA
phone: +USA (386) 418-2000 • fax: +USA (386) 418-2001
www.Sabine.com